

## Important – Read Me First

### For Oasis Resin Oval and Round Pools

## SECTION 4 Installing the Top Rails & Verticals

When you come to Section 4, page 4-3 in the Pool Frame Installation Manual, insert the following information BEFORE Step 3:

### 3. Install the Resin Rail Supports

- a. If your pool has an **Overlap Liner**: clip two 6" or one 10" resin rail support(s) (key 30) **over the plastic coping** on the top edge of the wall. Position either two 6" or one 10" midway between the top plates. Repeat this for each top plate around the whole pool.
  
- b. If your pool has a **Hung Liner** or a **V-Bead Liner**: clip two 6" or one 10" resin rail support(s) (key 30) **over the slotted metal tube** on the top edge of the wall. Position either two 6" or one 10" midway between the top plates. Repeat this for each top plate around the whole pool.

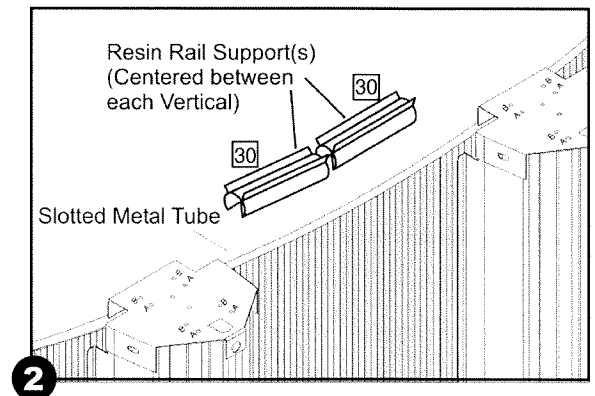
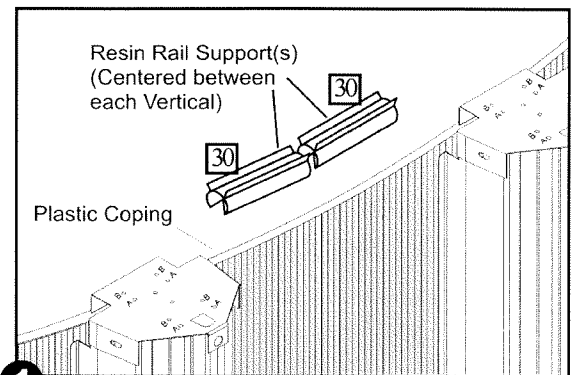

When you come to Section 2, page 2-7 in the Gibraltar Installation Manual or page 2-8 in the Channel Lok I Installation Manual, REPLACE Step 3(c) with the following:

### 3. Install the Top Rails

- a. **Important:** the four transition A top rails are marked with a **coloured dot** and the ends are mitred. For the transition A top rail, use hole 'A' in the top plate as shown in diagram 4. Fasten through the two oval holes to the top plate below with two 5/8" (15.8mm) self-tapping screws (key 32).

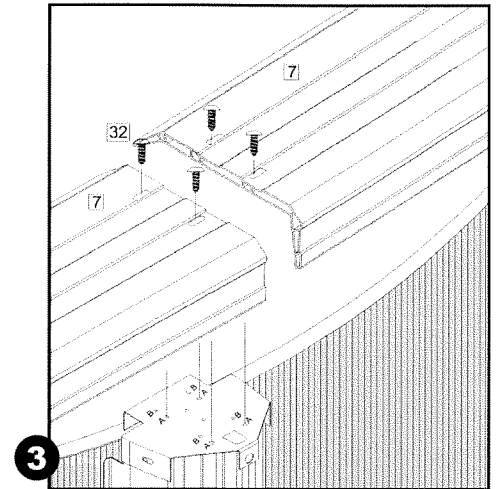

When you come to Section 4, page 4-4 in the Pool Frame Installation Manual, REPLACE Step 4 (d) with the following:

### 4. Install the Top Connectors

- d. **Important:** fasten the top connectors in place using the upper pair of holes in each vertical column (the upper holes are 3/8" (9 mm) above the lower holes).

