

# WATERFORD SYSTEMS HIGH RATE SAND FILTER SYSTEM

For Above Ground Swimming Pools

O W N E R ' S M A N U A L

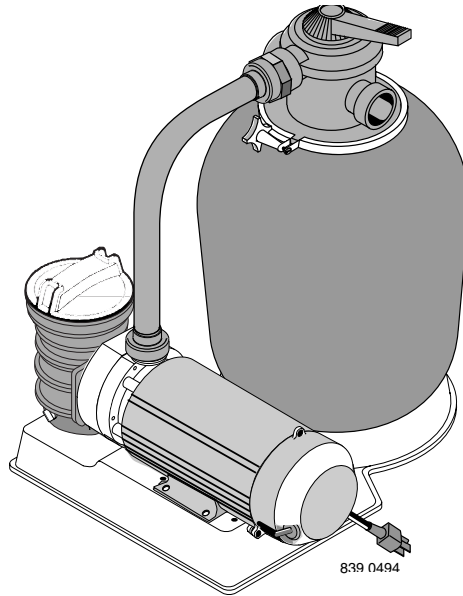

---

## INSTALLATION, OPERATION & PARTS

### Models

	15" Tank	18" Tank	21" Tank
3/4 HP	JSAL15D	JSAL180D	JSAL210D
1 HP	JSAL15E	JSAL180E	JSAL210E
1 HP (2-Speed)		JSAL180E	JSAL210E
1-1/2 HP		JSAL180F	JSAL210F

This manual should be furnished to the end user of this system; its use will reduce service calls and chance of injury and will lengthen system life.

### Sta-Rite Pool/Spa Group

293 Wright Street, Delavan, WI 53115

North America: 800-752-0183, FAX 800-582-2217

International: 262-728-5551, FAX: 262-728-4461, TELEX: ITT 4970245

[www.sta-ritepool.com](http://www.sta-ritepool.com)

Union City, TN • Delavan, WI • Mississauga, Ont. • Murrieta, CA

© 2003, Printed in U.S.A



S260 (Rev. 6/3/03)

# HIGH-RATE SAND FILTER SYSTEM

To avoid unneeded service calls, prevent possible injuries, and get the most out of your filter, READ THIS MANUAL CAREFULLY!

## The High Rate Sand Filter System:

- Is designed to circulate and filter water in above ground swimming pools.
- Offers quiet, efficient performance and is durable, reliable.
- With a 3' cord or no cord, use with permanently installed pools ONLY (see CAUTION #7, below).
- With a 25' cord, use with storable pools ONLY (see CAUTION #8, below).

## Table of Contents

Safety Instructions.....	3
Specifications/Dimensional Data .....	4
General Information.....	5
Installation.....	5-7
Filter Mount/Piping .....	5
Filter Set-up .....	6
Loading Sand Media .....	6
Valve Installation .....	6-7
Electrical.....	7
Startup/Operation/Backwash.....	8-9
Maintenance.....	9
Storage/Winterizing .....	10
Multi-Port Valve Service .....	11
Valve Removal.....	11
Pump Service.....	11-12
Troubleshooting Guide .....	13
Repair Parts List .....	14-17
Warranty.....	18

## IMPORTANT SAFETY INSTRUCTIONS

When installing and using electrical equipment, basic safety precautions should always be followed, including the following:

### 1. READ AND FOLLOW ALL SAFETY INSTRUCTIONS.

2. **▲ WARNING** To reduce the risk of injury, do not permit children to use this product unless they are closely supervised at all times.
3. **▲ WARNING** Risk of electrical shock. Connect only to a grounding type receptacle protected by a ground-fault circuit-interrupter (GFCI). Contact a qualified electrician if you cannot verify that the receptacle is protected by a GFCI.
4. Do not bury cord. Locate cord to minimize abuse from lawn mowers, hedge trimmers, and other equipment.
5. **▲ WARNING** To reduce the risk of electrical shock, replace a damaged cord immediately.
6. **▲ WARNING** To reduce the risk of electrical shock, do not use an extension cord to connect unit to electrical supply; provide a properly located outlet.

7. **▲ CAUTION** Permanent pumps are for use with permanently installed pools and may also be used with hot tubs and spas if so marked. Do not use with storable pools. A permanently installed pool is constructed in or on the ground or in a building such that it cannot be readily disassembled for storage. A storable pool is constructed so that it may be readily disassembled for storage and reassembled to its original integrity.
8. **▲ CAUTION** Storable pool pumps are for use with storable pools only. Do not use with permanently installed pools. A storable pool is constructed so that it is capable of being readily disassembled for storage and reassembled to its original integrity. A permanently installed pool is constructed in or on the ground, or in a building, such that it cannot be readily disassembled for storage.

**SAVE THESE INSTRUCTIONS**

# READ AND FOLLOW SAFETY INSTRUCTIONS!

**⚠** This is the safety-alert symbol. When you see this symbol on your valve or in this manual, look for one of the following signal words and be alert to the potential for personal injury.

**⚠ DANGER** warns about hazards that **will** cause serious personal injury, death or major property damage if ignored.

**⚠ WARNING** warns about hazards that **can** cause serious personal injury, death or major property damage if ignored.

**⚠ CAUTION** warns about hazards that **will** or **can** cause minor personal injury or property damage if ignored.

The label **NOTICE** indicates special instructions which are important but not related to hazards.

**Carefully read and follow all safety instructions in this manual and on system.**

Keep safety labels in good condition.  
Replace missing or damaged safety labels.

**⚠ WARNING** **Hazardous pressure**  
**Incorrectly installed or tested equipment may fail, causing severe injury or property damage.** Read and follow instructions in owner's manual when installing and operating equipment. Have a trained pool professional



perform all pressure tests.

1. Do not connect system to a high pressure or city water system.
2. Use equipment only in a pool or spa installation.
3. Trapped air in system can cause explosion. BE SURE all air is out of system before operating or testing equipment.

**Before pressure testing, make the following safety checks:**

- Check all clamps, bolts, lids, and system accessories before testing.
- BE SURE all air is out of system before testing.
- Tighten Sta-Rite trap lids to 30 ft. lbs. (4.1 kg-cm) torque for testing.
- Water pressure for test must be less than 25 PSI (172 kPa).
- Water temperature for test must be less than 95° F. (35° C).
- Limit test to 24 hours. After test, visually check system to be sure it is ready for operation. Remove trap lid and retighten hand tight only.

**NOTICE:** These parameters apply to Sta-Rite equipment only. For non-Sta-Rite equipment, consult manufacturer.

	<p><b>⚠ DANGER</b></p> <p><b>Hazardous Pressure!</b> <b>Can cause tank explosion.</b></p>	<p><b>WHEN USING SYSTEM:</b></p> <p>Do not test with compressed air or operate above rated pressure.</p>
	<p><b>⚠ DANGER</b></p> <p><b>Hazardous suction.</b> <b>Can trap or tear hair or body parts, causing severe injury or death.</b></p>	<p><b>WHEN USING SYSTEM:</b></p> <p>Do not block pump suction or pool main drain.</p>
	<p><b>⚠ WARNING</b></p> <p><b>Hazardous voltage.</b> <b>Can shock, burn, or cause death.</b></p>	<p><b>BEFORE WORKING ON PUMP OR MOTOR:</b></p> <p>Unplug pump motor.</p>

**TABLE I - OUTLINE DIMENSIONS IN INCHES (mm)**

Filter Model	A	B	C	D	E
15"(406mm) Filters	24 (610)	30-7/8 (784)	15-3/4 (400)	21-11/16 (551)	26-1/16 (662)
18"(457mm) Filters	26-9/16 (675)	33-5/16 (846)	17-3/4 (451)	24-1/4 (616)	27-1/16 (692)
21" (508mm) Filters	28-11/16 (729)	34-7/16 (875)	20-3/4 (527)	26-3/8 (670)	28-9/16 (725)

**TABLE II - FILTER SPECIFICATIONS AND OPERATING INFORMATION**

FILTER MODEL:	15" (JSAL15 Series)	18" (JSAL180 Series)	21" (JSAL210 Series)
Effective Filter Area	1.26 Ft. <sup>2</sup> (.117M <sup>2</sup> )	1.57 Ft. <sup>2</sup> (.223M <sup>2</sup> )	2.18 Ft. <sup>2</sup> (.203M <sup>2</sup> )
Max. Flow Rate	25.2 GPM(95 L/m)	31.5 GPM(123 L/m)	43.6 GPM(165 L/m)
Max. Operating Pressure	50 PSI(345 kPa)	50 PSI(345 kPa)	50 PSI(345 kPa)
Max. Operating Temperature	95° F(35°C)	95° F(35°C)	95° F(35°C)
Turnover in Hours:			
6 Hours	9,070 Gal.(34 330 liters)	11,340 Gal.(42 922 liters)	15,700 Gal.(59 424 liters)
8 Hours	12,100 Gal.(45 799 liters)	15,120 Gal.(57 229 liters)	20,930 Gal.(79 220 liters)
10 Hours	15,120 Gal.(57 229 liters)	18,900 Gal.(71 536 liters)	26,160 Gal.(99 016 liters)
12 Hours	18,144 Gal.(68 675 liters)	22,680 Gal.(85 844 liters)	31,390 Gal.(118 811 liters)
Qty. of Media Required:			
Cu. Ft. (cm <sup>3</sup> )	1(28 320cm <sup>3</sup> )	1.5(42 255cm <sup>3</sup> )	2(56 923cm <sup>3</sup> )
Weight in lbs.(kg)	100(45,4 kg)	150(68 kg)	200(90,7 kg)

**NOTE:** 1 cubic foot (28 320 cm<sup>3</sup>) of sand weighs approximately 100 lbs. (45,4kg). DO NOT use a finer grade of sand than recommended.

**RECOMMENDED SAND GRADES:**

Use only: #20 Silica Sand, Size Range .40-.55mm., Uniformity Coefficient less than 1.75.

**NOTICE:** Use of other sands will reduce filter performance, may damage pump, and will void warranty.

Recommended:

1. Wedron Silica/Best Sand Co., Sand Grade: Wedron .45-.55mm., Effective Size .46mm, Uniformity Coefficient 1.22.
2. U.S. Silica - Silurian Filter Sand, Sand Grade.45-.55 mm., Effective Size .48mm, Uniformity Coefficient 1.18.

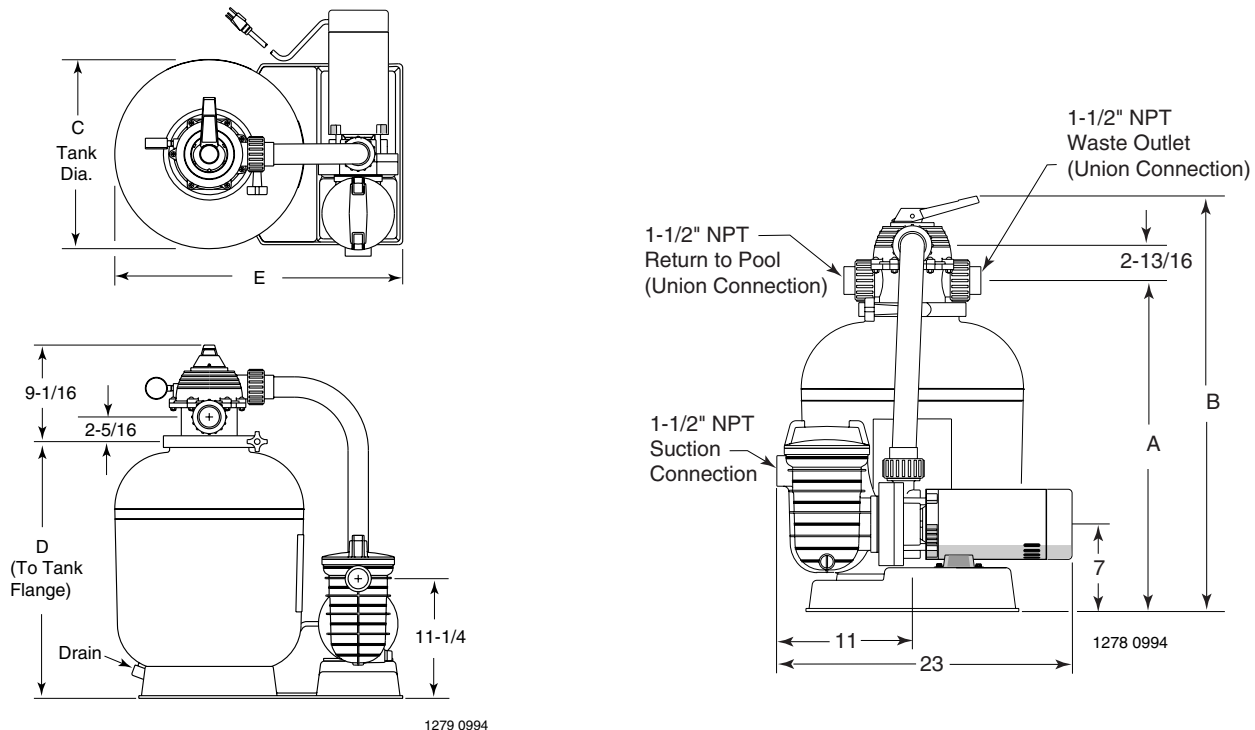

**Figure 1: Dimensions**

## GENERAL INFORMATION

- Clean a new pool as well as possible before filling pool and operating filter. Excess dirt and large particles of foreign matter in the system can cause serious damage to the filter and pump.

**⚠ NEVER test this filter with compressed air.**

**⚠ Do not operate filter at water temperatures above 95°F (35°C).**

**⚠ NEVER operate this filter system at more than 50 pounds per square inch (50 PSI/345 kPa) pressure!**

**⚠ Plug system into electrically isolated, Ground Fault Circuit Interrupter protected circuit ONLY!**

- Clean a new pool as well as possible before filling pool and operating filter. Excess dirt and large particles of foreign matter in the system can cause serious damage to the filter and pump.
- Keep pool water pH at recommended level (7.2 to 7.6) to avoid irritation to eyes and skin.
- The Hi-Rate Sand Filter System is designed for use with above ground swimming pools only.
- Use only #20 Silica sand with a screen mesh of .45 to .55mm. Use of other sands will reduce filter performance.

**⚠ CAUTION** To reduce risk of electric shock, install pump at least 10 feet from the inside wall of the pool. Do not use an extension cord.

## INSTALLATION

### Trap to Pump Assembly:

Using four 5/16" cap screws, flat washers and lockwashers, mount trap to pump body; be sure to install gasket between trap and pump body. Tighten cap screws to 80 inch-lbs (92 cm-kg) torque; do not overtighten.

### Filter Mount Must:

- Provide weather and freezing protection.
- Provide space and lighting for easy access for routine maintenance. (See Table I and Figure 1, Page 4, for space requirements.)
- Be on a reasonably level surface and provide adequate drainage.
- Be as close to pool as possible to reduce line loss from pipe friction.
- Be solid – level– rigid – vibration free.
- Be installed so that trap suction inlet is below pool water level at all times. This allows pump to prime.
- Have adequate ventilation to prevent motor overheating.

### Piping:

- Use teflon tape or Plasto-Joint Stik<sup>1</sup> on all male connections of plastic pipe and fittings except unions. **DO NOT use pipe compounds on plastic pipe; it will cause the pipe to crack.** Do not use sealant or tape on unions – assemble them dry and hand tight.
- Do not damage union sealing surfaces and “O” Rings.
- Support pipe independently to prevent strains on filter and valve.
- Use 1-1/2 or 2” pipe to reduce pressure losses as much as possible. If flex hose is used, use the type with smooth internal walls.
- Fittings restrict flow; for best efficiency use fewest possible fittings.
- Keep piping tight and free of leaks: pump suction line leaks may cause trapped air in filter tank or loss of prime at pump; pump discharge line leaks may show up as dampness or jets of water.
- When unions are provided, use as follows for leak free connections:
  1. O-Ring and sealing surfaces must be clean.
  2. Assemble hand tight only (**no wrenches**).
  3. No pipe compound or teflon tape on unions.

### Valves:

- For servicing filter system and for cleaning pump trap, install ball or gate valves
  - A. Between pump trap and pool skimmer, and
  - B. Between selector valve and return pipe to pool.
- A check valve installed between filter and heater will prevent hot water from backing up into filter and deforming internal components.
- Use care before assembly not to damage union sealing surfaces or O Ring.

### Wastewater:

- Be sure all provisions for waste water disposal meet applicable local, state or national codes. 100 gallons (379 liters) or more of pool water will be discharged during filter backwashing. Do not discharge where water will cause flooding or damage.

<sup>1</sup> Lake Chemical Co., Chicago, IL

## Filter Setup

**Assembly:** See Figures 2 through 5 for filter assembly.

### Loading Sand Media

1. To keep sand out of collector assembly, place plastic sand shield over top of collector tube before pouring sand into filter (See Figure 5).
2. To support laterals and prevent lateral breakage during loading, fill tank about half full of water before loading sand.
3. Pour sand into filter tank. See "Recommended Sand Grades", Page 4, for correct type and quantity of sand to use.

**NOTICE:** Make sure gasket area on top of tank is free of sand before installing valve and clamp.

4. Before installing valve, double-check that correct quantity of sand has been loaded (see Page 4).
5. Remove plastic sand loading shield and keep for future use.

### Valve Installation:

See Figures 6, 7, and 8

1. Install O-Ring on valve flange; make sure O-Ring is clean, dry, and has no nicks, tears, or scrapes.
2. Make sure tank and valve flanges are clean and free of sand; put valve on top of tank. Vertical pipe of collector assembly inserts into base of valve.
3. Install clamp; make sure knob is positioned for easy access for filter maintenance. Valve port labeled

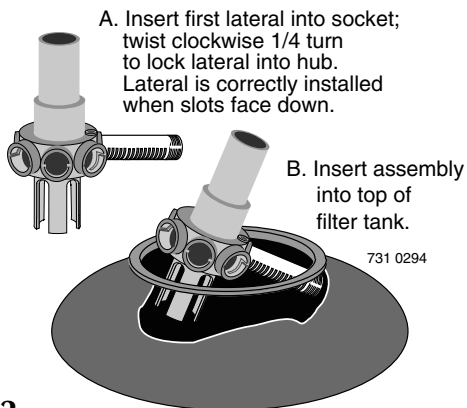

Figure 2

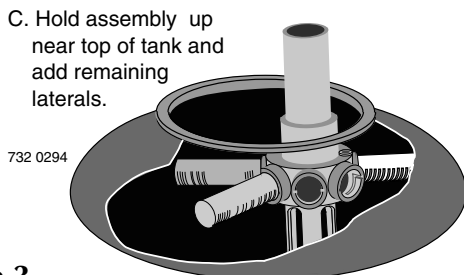

Figure 3

- "PUMP" should point toward pump.
4. Tighten clamp knob until clamp ends (under bolt) are 1/4" (6mm) apart. Tap around outside of clamp with a mallet to help seat clamp.

**⚠ WARNING** Hazardous pressure. Clamp will not hold unless it is seated properly! DO NOT START PUMP until clamp ends are 1/4" (6mm) apart or less.

5. If clamp will not pull up to 1/4" (6mm) gap, wait 15-30 minutes and retighten. Tap clamp gently with mallet to help seat clamp.
6. Connect pipe from pump discharge to valve port labeled "PUMP"; use union half provided. Assemble union as follows for leakfree operation:
  - A. O-Ring and sealing surfaces must be clean.
  - B. Assemble hand tight only (no wrenches).
  - C. NO pipe compound or teflon tape on unions.
7. Complete all plumbing connections (see Page 5 for piping requirements).
  - A. Pipe from valve RETURN port to pool return.
  - B. Pipe from valve WASTE port to waste.
  - C. Suction piping from pool to trap inlet on pump.

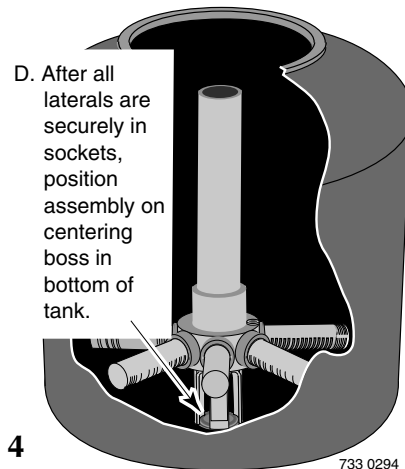

Figure 4

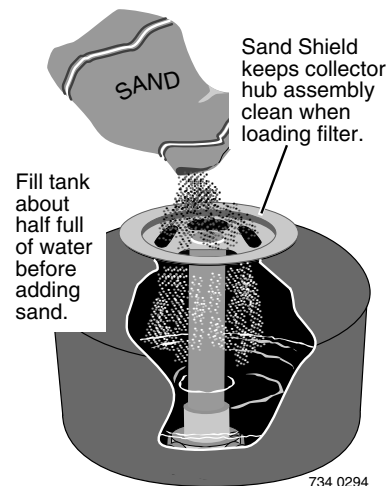
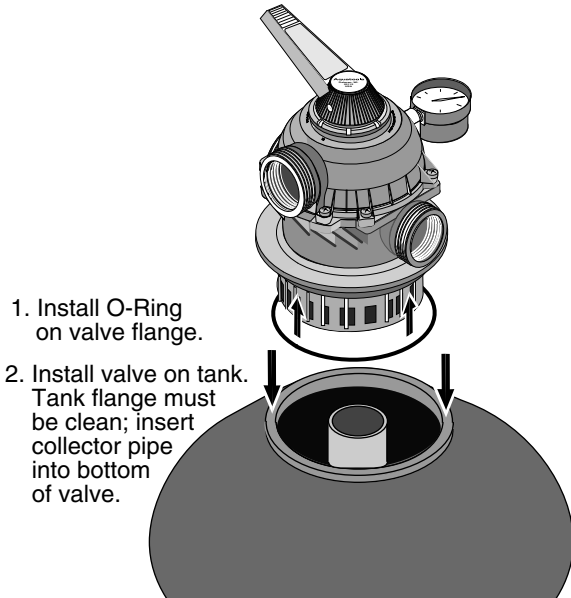

Figure 5

8. System is ready for startup.

**NOTICE:** If there are leaks from beneath valve/clamp area, STOP PUMP, release all pressure, remove clamp and valve and clean sealing surfaces.

Follow directions under "Valve Installation", Page 6, when reinstalling valve. See Figures 6 and 7.



**Figure 6**

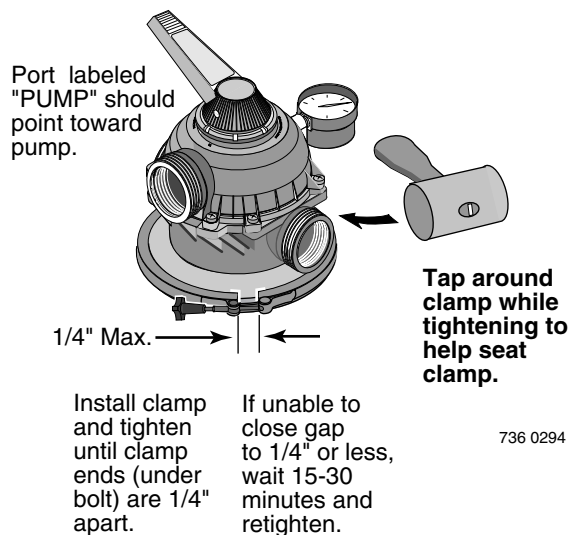

**Figure 7**

## ELECTRICAL

**⚠ WARNING**



**⚠ Risk of electrical shock. Plug pump into a grounded, GFCI-protected 115 Volt circuit only. Incorrect voltage can cause fire or seriously damage motor and voids warranty. Protect cord from water and physical damage.**

**⚠ GFCI tripping indicates an electrical problem. If GFCI trips and will not reset, have a qualified electrician inspect and repair electrical system.**

**⚠ WARNING Risk of electrical shock. Unplug motor before servicing or repairing pump or motor.**

**Hazardous voltage. Can shock, burn, or cause death.**

Disconnect power before working on pump or motor.

### Wiring:

Install a Ground Fault Circuit Interrupter (GFCI) in circuit; it will sense a short-circuit to ground and disconnect power before it becomes dangerous to pool users. For size of GFCI required and test procedures for GFCI, see manufacturer's instruction.

In case of power outage, check GFCI for tripping (which will prevent normal water circulation). Reset if necessary.

Match circuit breaker size to Table III, Page 8.

- Do not modify cord, plug, or receptacle. If an existing circuit must be used and the receptacle and plug do not match exactly, consult a licensed electrician.
- Do not use an extension or drop cord with this system; it could cause a fire hazard or low voltage problems. Wet cords cause shock hazards. Extension cords can easily become cut or frayed and dangerous when placed across yard areas or walkways.

### Voltage:

Voltage at motor must be not more than 10% above or below motor nameplate rated voltage or motor may overheat, causing overload tripping and reduced component life. If voltage is less than 90% or more than 110% of rated voltage when motor is running at full load, consult power company.

Table III–Recommended Fusing Data, 115 Volt 60 Hz Motors.

Pump Model No.	Motor H.P.	Full Load Amps	Branch Circuit Breaker Rating (Amps)
JWPA5DC-2A3	3/4	9.4	15
JWPA5EC-2A3	1	11.9	15
JWPS5FC-2A3	1-1/2SPL	11.9	15
17290-J1002 (2-Speed)	1 – 1/6	11.6/3.3	15

**NOTICE:** Values given are for pump motor only. Do not put any other accessories on this circuit.

Table IV–Recommended Fusing Data, 115 Volt 60 Hz Single Speed Motors.

Pump Model No.	Motor H.P.	Full Load Amps	Branch Circuit Breaker Rating (Amps)
JWPA5DL-2A1, -2A2	3/4	9.0	15
JWPA5EL-2A1, -2A2	1	12.0	15
JWPAS5F-2A4U	1-1/2 SPL	12.0	15
JWPA5FL-2A1, -2A2	1-1/2	16.0	20

Table V–Recommended Fusing Data, 230 Volt 60 Hz Motors.

Pump Model No.	Motor H.P.	Full Load Amps	Branch Circuit Breaker Rating (Amps)
JWPA5E-230A2	1	6.1	15

Table VI–Recommended Fusing Data, 115 Volt 60 Hz 2-Speed Motors.

Pump Model No.	Motor H.P.	Full Load Amps	Branch Circuit Breaker Rating (Amps)
JWPA5YEL	1 / 1/8	11.7/3.39	15
JWPA5YFL	1-1/2 / 1/6	16.6/3.6	25

**NOTICE** Values given are for pump motor only. Do not put any other accessories on this circuit.

## Startup/Operation (See Figure 9)

**⚠ DANGER** Hazardous suction. Can trap and tear hair or body parts and can cause drowning. Do not block pump suction. Small children using pool must ALWAYS have close adult supervision.

### Valve Setting Purpose/Flow



#### **FILTER**

Normal filtration and vacuuming; water goes through filter to pool.



#### **RINSE**

For initial startup cleaning and sand bed leveling after backwash; water goes through filter to waste.

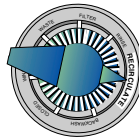

#### **RECIRCULATE**

Circulates pool water; bypasses filter.

737 0294

### Valve Setting Purpose/Flow



#### **BACKWASH**

Reverses flow for cleaning; water goes through filter to waste.



#### **CLOSED**

Shuts off all flow to filter and pool.

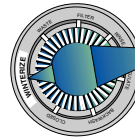

#### **WINTERIZE**

Leaves all valve ports partially open for winter storage.

738 0294

Figure 8

**NOTICE:** Determine circuit breaker rating from Table III, above.  
Determine correct outlet required from illustration below.

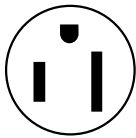

JWP 3/4 and 1 HP Models with -2A2 and -A2U suffix and 1-1/2 HP Models with -2A4U suffix use 15-amp straight outlet, above.

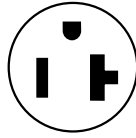

JWP 1-1/2 HP Models with -2A2 and A2U suffix use 20-amp straight outlet, above.

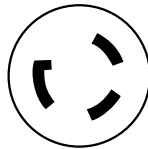

All JWP Models with -2A1 suffix use 20-amp twist-lock outlet, above.



**⚠ WARNING** Hazardous pressure. To avoid explosion and possible severe or fatal injury, filter system pressure must not exceed 50 PSI (345 kPa) under any circumstances. NEVER test this filter system with compressed air; never operate system with water temperature above 95° F (35° C).

**⚠ CAUTION** To prevent equipment damage and possible injury, turn pump OFF before changing valve position.

**NOTICE:** Do not add chemicals directly into the pool skimmer. Adding undiluted chemicals may damage equipment and void warranty.

1. Open system valves and make sure pump is filled with water.  
Make sure pool water level is above skimmer or the suction outlet.
2. With pump OFF, set valve to 'BACKWASH' position.
3. Start pump, circulating water backwards through filter to waste.
4. Backwash until water runs clear (3-5 minutes).
5. Stop pump; set valve to 'RINSE' position.
6. Start pump; run pump for one minute.
7. Stop pump; set valve to 'FILTER' position.
8. Filter is now ready for service.
9. Record clean starting filter pressure gage reading as a reference.
10. When pool is first filled, backwash once a day until pool water is sparkling clear. After that, backwash when pressure gage shows 5 to 7 PSI (34.5 to 48 kPa) higher than starting pressure.

**Valve Setting      Purpose/Flow**

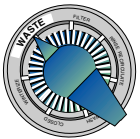

**WASTE**

Lowers pool level or drains pool; water bypasses filter, goes to waste.

743 0294



**Figure 9: Valve settings for startup. Stop pump before changing valve position.**

## MAINTENANCE

### General:

- Wash outside of filter with a mild detergent and water. Rinse off with hose.  
**NOTICE:** DO NOT use solvents to clean filter; solvents may damage plastic components in system.
- Inspect sand bed at least once a year to remove foreign material which has not been backwashed out of system.  
**NOTICE:** When the sand bed gets hard and crusty on top, remove all the old sand and replace it with new sand.

### Weekly Pool Equipment Inspection:

1. Check pressure during operation. When pressure is 5 to 7 PSI (34.5 to 48 kPa) higher than initial operating pressure, backwash filter (see instructions under "Startup/Operation").
2. Except during hot weather with heavy swimmer loads, operating filter 6 to 12 hours per day should be sufficient. Carefully monitor water chemical balance and follow recommendations of your local pool professional.

### Water Maintenance

- Keep water level at least two inches above bottom of skimmer opening when system is not in operation. Failure to do so can allow air to enter system, causing pump to lose prime and filter to entrap air.
- Maintain pH at 7.2 to 7.6 in pool.

**⚠ To prevent damage to system components, keep water temperature below 95° F (35° C) at all times.**

### Vacuum Pool:

1. Fill vacuum hose by submerging in water from one end to the other.
2. To vacuum, insert hose into skimmer suction manifold or into vacuum line in pool wall. See instructions provided by pool builder or pool manufacturer. Start pump, making sure it is primed and pumping.
3. After vacuuming, clean pump trap to remove accumulated debris, then check filter pressure gage. If reading is 5 to 7 PSI (34.5 to 48 kPa) higher than initial operating pressure, backwash filter

### Lower or Drain Pool

(See Figure 10, Page 10)

1. Turn pump 'OFF'; set valve handle to 'WASTE'.
2. Use vacuum cleaner hose and head.
3. Start pump; run until pool is lowered to desired level.
4. Turn pump 'OFF'; set valve handle to 'FILTER'.
5. Start pump.

## STORAGE/ WINTERIZING

**CAUTION** Pool chemicals may give off corrosive fumes. Store chemicals away from system in a well ventilated area.

**NOTICE:** Allowing water to freeze will damage filter and void warranty. If antifreeze is needed, use propylene glycol; it's plastic compatible and non-toxic. Follow manufacturers instructions. Do not use ethylene glycol based anti-freeze – it's toxic and it may damage plastic components.

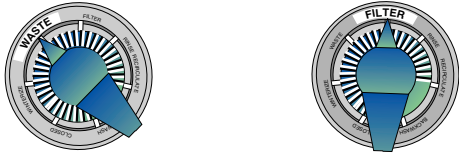

**Figure 10: Valve settings to lower pool water level. Stop pump before changing valve position.**

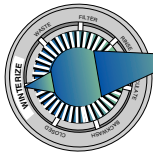

**Figure 11: Valve setting for winter storage. Stop pump before changing valve position.**

1. Open all system valves. Set multiport valve at 'WINTERIZE' to allow air passage to all ports (Figure 11).
2. Remove drain plug from filter.
3. Drain filter tank completely and replace drain cap (Figure 12).
4. Cover with plastic or tarpaulin to protect from weather.
5. Remove drain plugs from pump.
6. Protect from freezing.

### Startup for Winterized Equipment:

1. Remove any temporary weather protection placed around system for shutdown.
2. See "Startup", Page 8, for reactivation of the filter.
3. Inspect all electrical wiring to pump for damage or deterioration over the shutdown period. Have a qualified serviceman repair/replace wiring as needed. Inspect and tighten all watertight connections.
4. Open all valves in suction and return piping.
5. Remove any winterizing plugs in system.
6. Drain all winterizing chemicals (if used) from system; flush system.
7. Close all drain valves and replace all drain plugs in system.
8. Fill pool with water to proper level (see pool manufacturer's instructions).

## Drain Fitting Installation/Removal

**NOTICE:** If pool is above height of filter, first close valves in pump suction and return lines to prevent draining pool. If there are no shutoff valves installed, disconnect suction and return lines and raise ends above pool water level.

**1. Installation:** See Figure 12.

### 2. To Drain Filter:

- A. Remove drain cap. Lateral tube should remain in place inside drain opening to prevent sand from draining out.
- B. Open union coupling on backwash port of Multi-Port valve. This will allow air into filter and allow water to drain from filter tank.
- C. Replace cap when tank is empty.

### 3. Removing Sand From Filter:

- A. Remove both drain cap and slotted lateral tube (see Figure 12). Sand and water will drain from tank.
- B. To completely flush filter tank of sand, remove top clamp and multiport valve and flush the inside of the tank with a hose.
- C. Thoroughly clean sand from all parts and from tank drain opening before reassembling drain fitting.

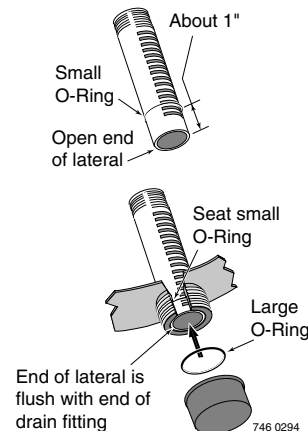

**Figure 12: Drain Fitting Assembly. This assembly allows water to drain without losing the sand out of the filter tank.**

**Make sure all surfaces are clean and free of sand. Don't cross thread cap; don't overtighten cap.**

## MULTI-PORT VALVE SERVICE

**⚠ WARNING** Hazardous pressure. Stop pump and release all pressure from system before working on filter, valve, or clamp.

**NOTICE:** If Multi-Port valve is below pool water level, close suction and discharge valves before disassembly to prevent draining pool.

### Handle Replacement:

1. Stop pump.
2. Place handle in 'FILTER' position.
3. Remove pin (Key 1, Figure 13) to disconnect handle. If it cannot be removed by hand, use a hammer and center punch and lightly tap it out.
4. Remove handle; replace with a new one. Be sure new handle is in 'FILTER' position.
5. Replace pin.

### Lid and Plug replacement:

**A. Remove Handle** (see 'Handle Replacement', above).

**B. Remove plug:**

1. Remove all screws and nuts (Key Nos. 2 and 6, Figure 13).
2. Remove lid (Key No. 3) by pulling straight up while holding plug shaft (Key No. 5) down with thumb.

**C. Inspect Internal Parts:**

Inspect plug and gasket spring, O-Rings, and internal washers (Key No. 4). Replace if necessary.

**D. Reassemble Valve:**

1. Replace plug gasket and shaft, mounting spring, washers, and O-Ring on plug shaft. Lubricate O-Ring with Amojel.
2. Replace lid; match screw holes in lid and body.
3. Press down on lid to allow screws to engage nuts; tighten each nut securely.
4. Replace top washer (Key No. 1A) and handle, making sure indexing pin on plug shaft points in same direction as pointer on handle. Replace handle pin.
5. Tighten all lid screws to 55 inch-lbs. (63.4 kg-cm) torque.

### Valve Removal

**⚠ WARNING** Hazardous pressure. Stop pump and release all pressure from system before working on filter, valve, or clamp.

**NOTICE:** If multi-Port Valve is below pool water level, close suction and discharge valves before disassembly to prevent draining pool.

1. Disconnect piping from pump and pool.
2. Remove clamp.

3. Remove valve from filter top.

4. To reinstall valve, follow "Valve installation" instructions, Page 6. BE SURE to follow clamp tightening instructions.

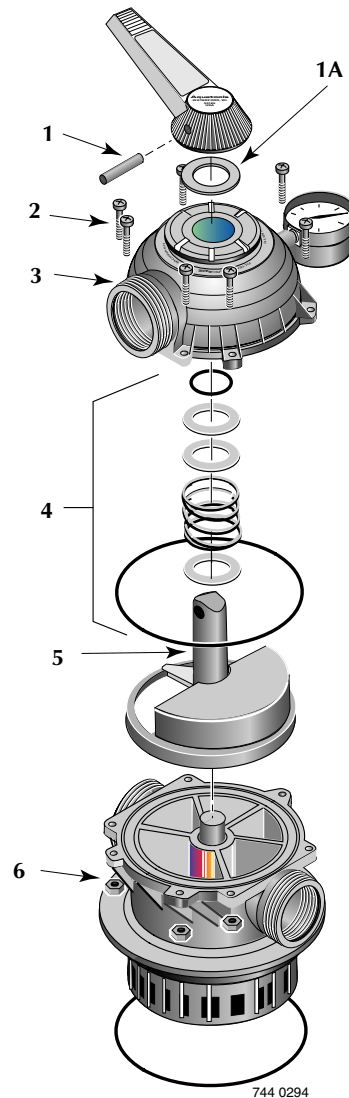

Figure 13: Valve Disassembly

## PUMP SERVICE

**⚠ CAUTION** To protect against possible electric shock, use only identical replacement parts when servicing. System should only be serviced by qualified personnel.

**⚠ Before removing trap cover:**

1. STOP PUMP before proceeding.
2. CLOSE GATE VALVES in suction and discharge pipes.
3. RELEASE ALL PRESSURE from pump and piping system.

**⚠ To avoid dangerous or fatal electrical shock hazard, turn OFF power to motor before working on pump or motor.**

Trap needs no lubrication or regular maintenance beyond reasonable care and periodic cleaning of strainer basket.

If shaft seal is worn or damaged, repair as follows:

**Pump Disassembly:**

1. Unplug motor before servicing or repairing pump or motor.
2. Close all valves in suction and discharge piping.
3. Remove drain plugs from the bottom of pump and trap; drain pump completely.
4. Disconnect pipe unions (or clamps) on suction and discharge piping. Remove hold down bolts and withdraw complete pump/motor/trap assembly.
5. Remove cap screws (Key No. 16, Pages 15 and 16) from front plate (Key No. 13). Remove front plate with trap (Key No. 20) attached. Remove and inspect O-Ring (Key No. 12).
6. Remove end cap (Key No. 2) from motor cover (Key No. 7). **NOTICE:** JWP Series pump motors do not have a motor cover or switch.
7. Hold motor shaft with 7/16" wrench on flats on motor shaft; unscrew impeller (Key No. 11).
8. Carefully remove rotating half of seal (Key No. 10) from impeller sleeve. Twist as you pull; make sure you do not damage surface of sleeve where seal both seats and seals. See Figure 14.
9. Remove motor throughbolts (see Figure 15). Remove seal plate (Key No. 9). Tap stationary half of seal out of seal plate (see Figure 16).
10. If necessary, disconnect electrical wiring from motor terminal board and remove motor (Key No. 6) from motor cover (Key No. 7).

**Pump Assembly:**

1. Examine seal cup and O-Rings. Replace anything that shows signs of wear or damage.
2. Check the shaft seal (Key No. 10, Pages 15 and 16) for scoring, scratches, chips, etc., and for any signs of damage to spring or retainer. Replace if any wear or damage is visible.

3. Press stationary half of seal into seal plate (Key No. 9) using finger pressure only (see Figure 17). Make sure seal is firmly and evenly seated.
4. Install rotating half of seal on impeller sleeve. Push it onto sleeve until it butts against back of impeller.
5. Insert impeller sleeve through center hole in seal plate (Key No. 9). Thread slinger (Key No. 8) over the end of the impeller sleeve.
6. If motor has been removed from motor cover, reinstall it now. Set up seal plate (Key No. 9) in front of motor cover; hold motor shaft with 7/16" wrench on shaft flats (under cap) and thread impeller through center hole in seal plate onto shaft). Make sure that slinger is in place on impeller sleeve – not loose on shaft.
7. Install motor throughbolts; make sure seal plate butts firmly against motor endbell. If necessary, install motor cover and switch.
8. Install wear ring on back of front plate. **NOTICE:** Teeth on wear ring interlock with ribs in front plate.
9. Install front plate (Key No. 13). Tighten cap screws in sequence as shown in Figure 18; tighten to 30 inch-lbs. (34.5 cm-kg.) torque.
10. Reinstall drain plugs; reinstall pump and motor on base and tighten hold-down bolts.
11. Reconnect unions; tighten **hand tight only**.

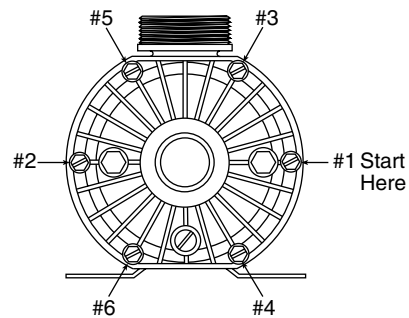

**Figure 18: Pump front Plate Torque Sequence.**



**Figure 14**

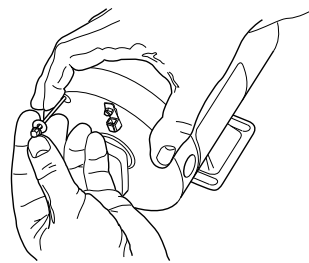

**Figure 15**

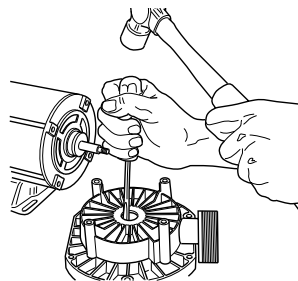

**Figure 16**

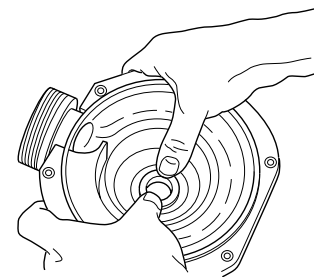

**Figure 17**

## TROUBLESHOOTING GUIDE – PUMP

**⚠ Read and understand safety and operating instructions in this manual before doing any work on pump.**

### A. Pump does not operate:

1. Check GFCI (Ground Fault Circuit Interrupter) for proper operation according to GFCI manufacturer's instructions.
2. Check for blown fuses, circuit breakers, or disconnected electrical wiring.
3. Check for sand locked impeller. Disconnect power to motor; follow "Pump Disassembly" instructions, Page 12. Clean out sand from impeller and from wear ring in front plate. Reassemble according to instructions, Page 12.
4. Consult dealer/installer or service representative.

### B. Motor runs, but does not pump water or pressurize system:

1. Check to make sure all valves are open.
2. Check skimmer, trap basket, and piping for debris or obstructions.
3. Check pump impeller for obstructions such as hair, leaves, grass, or stones. Follow "Pump Disassembly" instructions, under "Pump Service" on Page 12.
4. Consult with dealer/installer or service representative.

### C. Excessive air in system – pump loses prime:

1. Make sure water level in skimmer is at least 2" above bottom of skimmer throat with system not operating.
2. Make sure that there are no leaves in suction piping.
3. Make sure there is no vortex (whirlpool) at the suction; add water to pool if necessary.
4. Consult dealer/installer or service representative.

### D. Circuit breaker in home panel trips repeatedly:

1. Breaker must be of adequate capacity.
2. If breaker is a GFCI breaker, test according to GFCI manufacturer's instructions.
3. Be sure no other lights and appliances are on circuit.
4. Check wiring size leading to pump. Inadequate size wiring will cause overheating of pump and excessive amp draw leading to circuit breaker tripping.
5. Consult dealer/installer or service representative

## TROUBLESHOOTING GUIDE – FILTER

### A. Short Cycle between backwashes:

**NOTICE:** Time between backwashes will vary with each installation and between different areas of the country. Ask installer about normal backwash interval in your area. The following causes and remedies are for cycle times shorter than normal for your area.

1. Flow rate too high or filter too small; consult dealer for system sizing recommendations.
2. Water is chemically out of balance; consult pool serviceman.
3. Excess dirt/dust in pool; vacuum pool directly to waste.
4. Body oil/lotion build-up in filter; consult dealer for chemical filter cleaners and follow cleaner manufacturer's instructions.
5. Filter inadequately backwashed. See instructions under "Startup/Operation", Page 8.
6. Algae in pool. Consult pool professional about proper chemical maintenance.
7. Residual chlorine level too low. Consult pool professional about proper chemical maintenance.
8. Inspect filter sand for solidification caused by dust, calcium, skin oils, of suntan lotions.

### B. Low Flow:

1. Pipe blocked downstream from filter; remove obstruction.
2. Piping too small; use larger pipe (consult dealer for sizing).
3. Plugged pump; plugged hair and lint trap or skimmer basket. Clean thoroughly.

### C. Pool Water Not Clear:

1. Water is chemically out of balance; consult pool professional.
2. Filter is too small; consult dealer about equipment sizing.
3. Sand in pool means broken lateral. Drain both water and sand out of tank. Remove valve; follow procedure under "Filter Setup", Page 6, and instructions with new lateral to replace broken part.

**⚠ WARNING** To avoid severe injury or major property damage, follow instructions under 'Valve Installation', Figures 6, 7 and 8, Pages 6, 7 and 8).

1. Follow "Valve Removal" procedure, Page 11.
2. Replace lateral according to instructions supplied with new lateral.
3. Reassemble filter according to instructions under "Filter Setup", Page 6

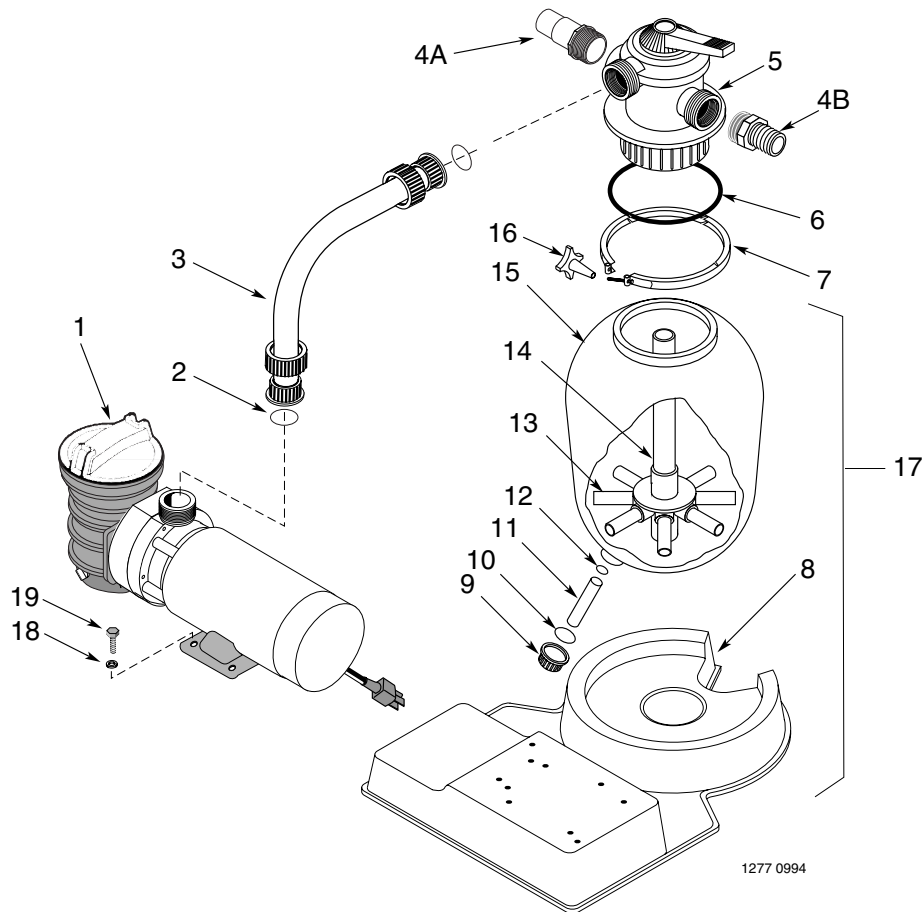

1277 0994

### Repair Parts List - Filter

Key No.	Part Description	No. Used	MODELS		
			JSAL15D JSAL15E 15" Filter	JSAL180D JSAL180E JSAL180E JSAL180F 18" Filter	JSAL210D JSAL210E JSAL210E JSAL210F 21" Filter
1	Pump* (Models with -06, -09 suffix)	1	JWP Series	JWP Series	JWP Series
1	Pump** (All other suffixes)	1	JWP Series	JWP Series	JWP Series
2	O-Ring	1	U9-226	U9-226	U9-226
3	Hose Assembly (Includes Key No. 2)	1	24203-0036	24203-0033	24203-0034
4A	Hose Adapter	2	11201-0002	11201-0002	11201-0002
4B	Sight Glass	1	14962-0012	14962-0012	14962-0012
5	Multiport Valve** (Includes Key Nos. 6, 7 and 16)	1	WC112-148A	WC112-148A	WC112-148A
6	O-Ring, Tank Flange	1	U9-369	U9-369	U9-369
7	V-Clamp with Knob	1	WC119-87A	WC119-87A	WC119-87A
8	Pedestal Platform	1	24201-0055P	24201-0055P	24201-0055P
9	Drain Cap	1	14965-0025	14965-0025	14965-0025
10	O-Ring, Drain Cap	1	U9-371	U9-371	U9-371
11	Drain Lateral Tube	1	24201-0058	24201-0058	24201-0058
12	O-Ring, Lateral Tube	1	U9-370	U9-370	U9-370
13	Lateral Tube	8	24600-0003	24600-0003	24600-0003
14	Collector Hub Assembly	1	24200-0110	WC137-516P	WC137-517P
15	Tank Assembly	1	24200-0100	24201-0100	24203-0100
16	Clamp Knob	1	WC36-22	WC36-22	WC36-22
17	Filter Tank Ass'y (Includes Key Nos. 8 thru 15)	1	24200-9100S	24201-9100S	24203-9100S
18	Washer 1/4"	2	U43-60SS	U43-60SS	U43-60SS
19	Screw 1/4-20x3/4" Lg.	2	U30-52SS	U30-52SS	U30-52SS
	• Hose, 1-1/2" x 6' Lg.***	2	34055-7038	34055-7038	34055-7038
	• Sand Shield	1	24201-0043	24201-0043	24201-0043
	• Nameplate Decal	1	32155-4115A	32155-4115B	32155-4115C
	• Clamp Decal, Warning	1	32165-4030	32165-4030	32165-4030
	• Information Decal	1	32155-4112	32155-4112	32155-4112

• Not illustrated.      \*See Page 15.      \*\*See Page 16.  
 \*\*\* Models JSAL15D-59, JSAL180F-05, and JSAL210F-05 do not include 6' hose.

**REPAIR PARTS LIST  
POOL PUMPS  
3/4 thru 1-1/2 HP Single Speed  
1 Hp Dual Speed**

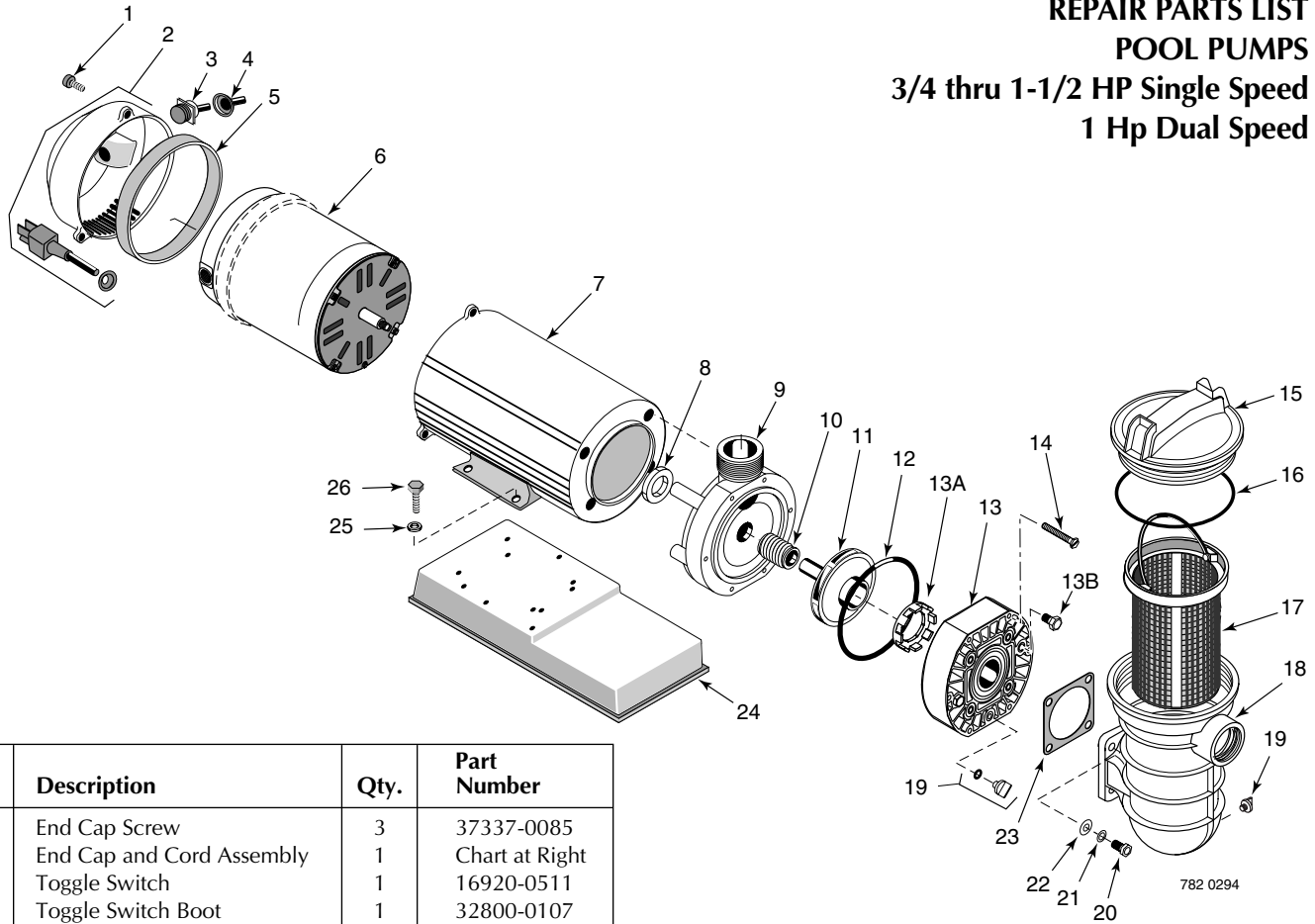

Key No.	Description	Qty.	Part Number
1	End Cap Screw	3	37337-0085
2	End Cap and Cord Assembly	1	Chart at Right
3	Toggle Switch	1	16920-0511
4	Toggle Switch Boot	1	32800-0107
5	Baffle Ring	1	17290-0004
6	Motor	1	Chart at Right
7	Motor Cover	1	17190-0021
8	Slinger	1	17351-0009
9	Seal Plate	1	C1-260P
10	Shaft Seal	1	37400-0027S
11	Impeller	1	Chart at Right
12	O-Ring	1	U9-357
13	Front Plate (Includes Key Nos. 13A, 13B, 19)	1	C101-272PS
13A	Wear Ring*	1	
13B	Pipe Plug	2	WC78-40T
14	Cap Screw	4	30387-0005
15	Trap Lid	1	C3-139P1
16	Trap Lid Gasket	1	U9-229
17	Trap Basket	1	C108-33P
18	Trap Body	1	C153-53P
19	Drain Plug w/O-Ring	2	U178-920P
20	Cap Screw	4	U30-64SS
21	Lock Washer	4	U43-11SS
22	Plain Washer	4	U43-41SS
23	Trap Outlet Gasket	1	C20-123
24	Mounting Foot	1	17190-0023
25	Plain Washer	4	U43-117SS
26	Cap Screw	4	U30-52SS
•	Nameplate	1	32155-4073
•	Decal – GFCI Required	1	U27-558
•	Decal – Insulated Wet End	1	U27-584
•	Tag – Do Not Use Pipe Dope	1	61002-0002
•	Tag – Caution	1	61002-0004

Parts are common to all models listed except as noted; Key Nos. 2, Cord & Cap Assembly; 6, Motor; and 11, Impeller, are listed below.

Model No.	HP	Motor No. (Key No. 6)	Impeller No. (Key No. 11)
<b>Single Speed</b>			
JWPA5DC-2A3	3/4	AS901DL	C105-228PWBS
JWPA5EC-2A3	1	AS901EL	C105-228PWS
JWPS5FC-2A3	1-1/2SPL	AS901SFL	C105-228PWS
<b>Dual Speed</b>			
17290-J1002	1 – 1/6	17182-0090	C105-228PWS
<b>Model No.</b>		<b>Cord &amp; Cap Assembly (Key No. 2)</b>	
<b>HP</b>			
JWPA5DC-2A3	3/4	17190-0026-S	
JWPA5EC-2A3	1	17190-0026-S	
JWPS5FC-2A3	1-1/2SPL	17190-0026-S	
<b>Dual Speed</b>			
17290-J1002	1 – 1/6	17190-0028-S	

Order PKG. 115 for 5" Trap complete (includes Key Nos. 17 through 25).

• Not illustrated.  
\* Not available separately.

# JWPA PUMPS

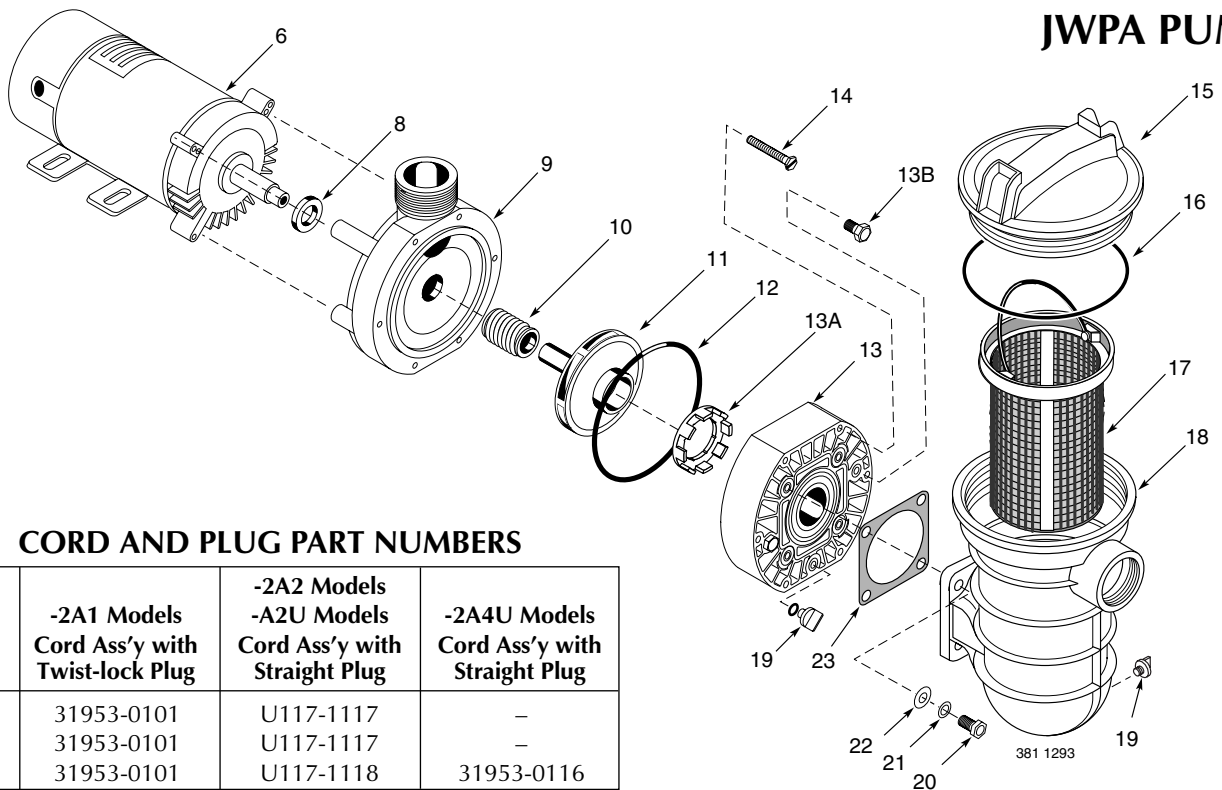

## CORD AND PLUG PART NUMBERS

HP	-2A1 Models Cord Ass'y with Twist-lock Plug	-2A2 Models -2A2U Models Cord Ass'y with Straight Plug	-2A4U Models Cord Ass'y with Straight Plug
3/4	31953-0101	U117-1117	-
1	31953-0101	U117-1117	-
1-1/2	31953-0101	U117-1118	31953-0116

## REPAIR PARTS LIST

Key No.	Description	Qty.	Model Number		
			JWPA5DL-2A1 JWPA5DL-2A2 3/4 HP	JWPA5EL-2A1 JWPA5EL-2A2 JWPA5E-230A2 JWPA5YEL-A2U 1 HP	JWPA5FL-2A1 JWPA5FL-2A2 JWPAS5F-2A4U JWPA5YFL-A2U 1-1/2 HP
6	Motor 115/60H/1Ph (Without Cord)	1	AS920DLL	AS920ELL	AS920FLL
6	Motor 230/60H/1Ph (Without Cord)	1	-	AS923EL	-
6	Motor 115/60H/1Ph 1-Speed (Without Cord)	1	-	-	62003-2031
6	Motor 115/60H/1Ph 2-Speed (Without Cord)	1	-	62003-2021	62003-2032
8	Slinger	1	17351-0009	17351-0009	17351-0009
9	Seal Plate	1	17301-0150	17301-0150	17301-0150
10	Shaft Seal	1	37400-0027S	37400-0027S	37400-0027S
11	Impeller	1	C105-228PH	C105-228PG	C105-228PG
12	O-Ring	1	U9-357	U9-357	U9-357
13	Front Plate (Includes Key Nos. 13A, 13B, 19)	1	C101-272PS	C101-272PS	C101-272PS
13A	Wear Ring*	1	-	-	-
13B	Pipe Plug	2	WC78-40T	WC78-40T	WC78-40T
14	Screw, 1/4-20x1-3/4	6	30787-0005	30787-0005	30787-0005
15	Trap Cover	1	C3-139P1	C3-139P1	C3-139P1
16	Strainer Basket	1	C108-33P	C108-33P	C108-33P
17	O-Ring - Cover	1	U9-229	U9-229	U9-229
18	Trap Body	1	C153-53P1	C153-53P1	C153-53P1
19	Drain Plug - 1/4" NPT (w/O-Ring)	2	U178-920P	U178-920P	U178-920P
20	Capscrew 5/16-18x1-1/4"	4	U30-64SS	U30-64SS	U30-64SS
21	Washer, Lock 5/16"	4	U43-11SS	U43-11SS	U43-11SS
22	Washer, Flat 5/16"	4	U43-41SS	U43-41SS	U43-41SS
23	Gasket	1	C20-123	C20-123	C20-123
•	Cord Assembly	1	See Chart Above	See Chart Above	See Chart Above
•	Nameplate	1	U33-155	U33-155	U33-155
•	Decal "Tested for Pools & Spas"	1	U27-635	U37-635	U27-635
•	Decal - GFCI required	1	U27-558	U27-558	U27-558
•	Tag - bonding instructions	1	C63-12	C63-12	C63-12
•	Tag - CAUTION Securely Tighten...Warning...	1	C63-13	C63-13	C63-13

• Not illustrated.

\* Not available separately.



# REPAIR PARTS LIST WC112-148A MULTIPORT VALVE

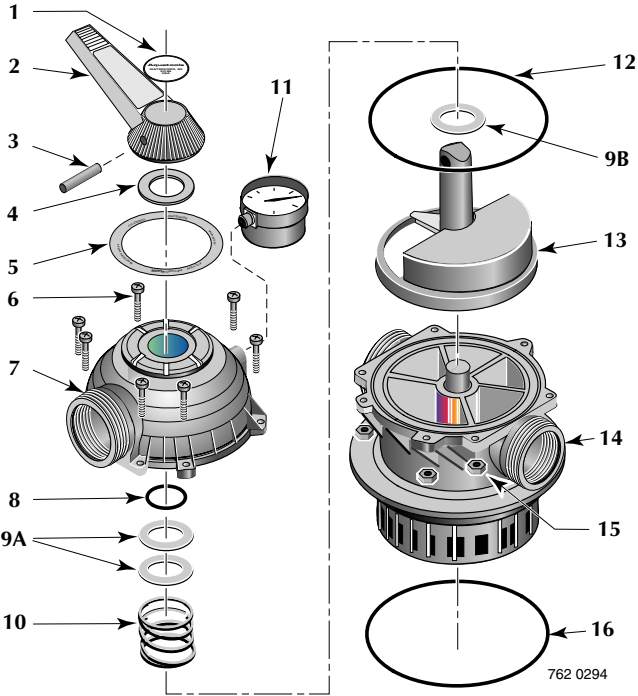

Key No.	Description	Qty.	Part Number
1	Decal, Valve Handle	1	32145-4016
2	Handle	1	14962-0032
3	Dowel Pin	1	35857-0021
4	Washer	1	14965-0007
5	Decal, Operating Instructions	1	14965-0020
6	Screw	7	37067-0714
7	Valve Cover	1	14965-0011
8	O-Ring	1	35505-1228
9A	Washer	2	14965-0007
9B	Washer	1	14965-0007
10	Spring	1	14965-0006
11	Pressure Gage	1	15060-0000T
12	O-Ring, Cover	1	35505-1275
13	Plug & Gasket Assembly	1	14965-0028
14	Valve Body Assembly	1	14965-0013
15	Nut	7	35407-0071
16	O-Ring, Tank Flange	1	U9-369

## STA-RITE LIMITED WARRANTY

Pumps, filters, skimmers, underwater lights (except bulbs), accessories and fittings manufactured by Sta-Rite are warranted to be free of defects in material and workmanship for one (1) year from date of installation.

Product specific warranties:	Year from date of installation
<i>HRPB, DEPB, System 3, and PL - Tanks</i> . . . . .	10 years
Internal filter components and valves . . . . .	1 year
<i>Max-E-Therm - Pool/Spa Heaters</i> . . . . .	2 years
Heater Enclosure only (Upper RH & LH; lower enclosure; and control board enclosure)...	10 years
<i>Automatic Pool Cleaners including Hose</i> . . . . .	2 years
<i>Cristal-Flo filters - Tanks</i> . . . . .	10 years pro-rated*
Valve and internal components. . . . .	1 year
<i>Posi-Flo II - Tanks</i> . . . . .	10 years
Elements . . . . .	1 year
<i>PRC Cartridge -</i>	
Filter Tanks . . . . .	5 years pro-rated (1st 2 years full)
Elements . . . . .	1 year
<i>System 2 Above Ground Systems - Tanks</i> . . . . .	10 years
Pumps / Platform and Internals . . . . .	1 year
<i>Pumps</i> . . . . .	1 year
When equipped with A.O. Smith 2-compartment motors (Does not include pumps sold as part of a systems package) . . . . .	2 years
<i>Traps / In-Line Strainers</i> . . . . .	1 year
<i>Vertical Commercial Filter - Tanks</i> . . . . .	10 years
Internals . . . . .	1 year
<i>Horizontal Commercial Filter</i>	
Tanks . . . . .	5 years
(Years 6-9, Prorated declining 20%/year, Yr. 10 - 10%)	
Internals . . . . .	1 year

\* Full warranty coverage is in effect for one year after installation. The pro-rated warranty covers the *tank only* during the 2nd through 10th year after installation. The amount covered decreases by 10% each year. (ie., 2nd year 90% covered, 3rd year 80% covered, etc.).

The foregoing warranties relate to the original consumer purchaser ("Purchaser") only. Sta-Rite shall have the option to repair or replace the defective product, at its sole discre-

tion. Purchasers must pay all labor and shipping charges necessary to replace the product covered by this warranty. Requests for warranty service must be made through the installing dealer. This warranty shall not apply to any product that has been subject to negligence, misapplication, improper installation or maintenance, or other circumstances which are not in Sta-Rite's direct control.

This warranty sets forth Sta-Rite's sole obligation and Purchaser's exclusive remedy for defective products.

STA-RITE SHALL NOT BE LIABLE FOR ANY CONSEQUENTIAL, INCIDENTAL OR CONTINGENT DAMAGES WHATSOEVER.

THE FOREGOING WARRANTIES ARE EXCLUSIVE AND IN LIEU OF ALL OTHER EXPRESS WARRANTIES. IMPLIED WARRANTIES, INCLUDING BUT NOT LIMITED TO THE IMPLIED WARRANTIES OF MERCHANTABILITY AND FITNESS FOR A PARTICULAR PURPOSE, SHALL NOT EXTEND BEYOND THE DURATION OF THE APPLICABLE EXPRESS WARRANTIES PROVIDED HEREIN.

Some states do not allow the exclusion or limitation of incidental or consequential damages or limitations on how long an implied warranty lasts, so the above limitations or exclusion may not apply to you. This warranty gives you specific legal rights and you may also have other rights which vary from state to state.

Supersedes all previous publications.

**Sta-Rite Industries, Inc.,**  
293 Wright St., Delavan, WI 53115

▲ Retain Warranty Certificate (upper portion) in a safe and convenient location for your records.

DETACH HERE: Fill out bottom portion completely and mail within 10 days of purchase/installation to:

▼ Sta-Rite, Attn: Warranty Dept., 293 Wright St., Delavan, WI 53115

**STA-RITE®**



## Warranty Registration Card

Name \_\_\_\_\_

Years pool has been in service  less than 1  1-3  3-5  5-10 \_\_\_\_\_

Address \_\_\_\_\_

Purchased from:  
Company name \_\_\_\_\_

City \_\_\_\_\_ State \_\_\_\_\_ Zip \_\_\_\_\_

Address \_\_\_\_\_

Purchase Date \_\_\_\_\_

City \_\_\_\_\_ State \_\_\_\_\_ Zip \_\_\_\_\_

Product Purchased \_\_\_\_\_

New installation  Replacement \_\_\_\_\_

Please send me more information on these other products from Sta-Rite.

Type of Pool  Inground  Vinyl  Fiberglass  Gunite \_\_\_\_\_

- Pumps  Filters  Automatic Pool Cleaners
- Maintenance Equipment  Test Strips
- Heaters

Size of Pool \_\_\_\_\_