

ROUND POOLS

6000 Series • 6500 Series • 7000 Series • 7100 Series 8000 Series • 8100 Series • 8500 Series • 9000 Series Installation Manual

PLEASE NOTE: In addition to this Installation Manual, your Owner's Package contains a **Parts Chart and Assembly Diagram** specially designed for your pool. Your Parts Chart can help you in the following ways:

- It lists all the parts you should receive with your pool.
- It contains assembly diagrams and parts descriptions specific to your pool.
- It will assist you in ordering parts should you ever need to do so.

From time to time, this manual will instruct you to review your Parts Chart and Assembly Diagram for more detailed information.

PLEASE!

Carefully read and review this manual entirely before you begin installation of your new Above Ground Pool. In some cases failure to follow the instructions will affect the stability and integrity of your pool and may void your warranty.

Before you begin assembly, we highly recommend you do the following:

- 1) Read all Safety Warnings.
- 2) Read all instructions.
- 3) Check the parts list and count all parts to make sure you have received the appropriate quantities.

If you find that you are missing parts, or encounter a problem with installation, contact our Customer Service Department at (410) 547-7303, Monday-Friday, 8:30 a.m.-4:30 p.m., EST.



THIS SYMBOL ALERTS YOU to areas of special importance throughout this installation manual. Please review these items carefully!

WARNING! Shallow Water!

Absolutely NO DIVING or JUMPING!
May cause permanent injury or death.

Your pool is approximately 4 feet deep. It is not designed for jumping or diving. If you jump or dive into this pool, you run a high risk of permanent injury or death. Make sure all users of this pool, including guests, are aware of this, and point out all warning labels!



SAFETY LABEL PLACEMENT

Your pool comes with four (4) pre-affixed Safety Labels. Care should be taken that Safety Labels are visible to all pool users at ALL TIMES!

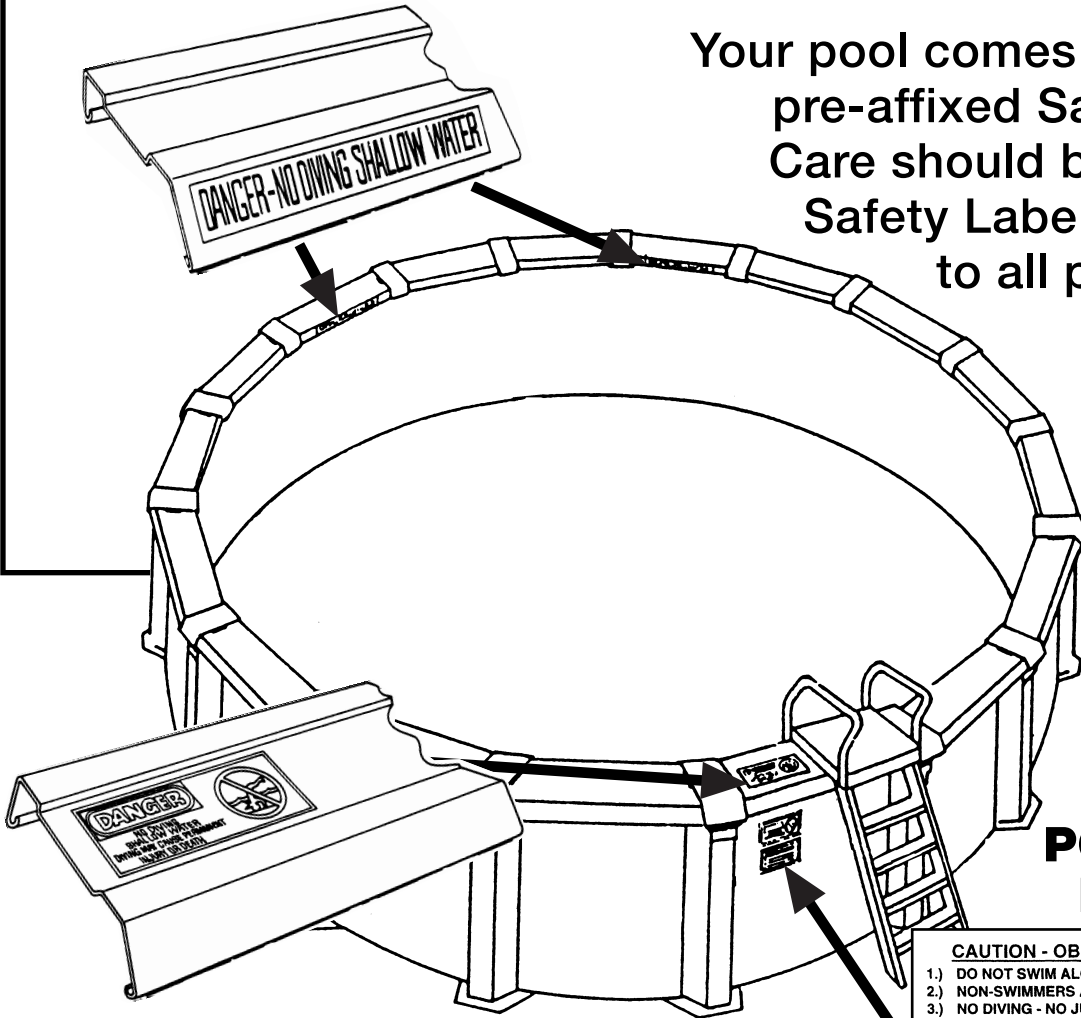

POINT OF ENTRY

CAUTION - OBSERVE THESE SAFETY RULES

- 1.) DO NOT SWIM ALONE. SUPERVISION IS MANDATORY.
- 2.) NON-SWIMMERS AND MINORS MUST NOT BE LEFT ALONE.
- 3.) NO DIVING - NO JUMPING - NO RUNNING - NO PUSHING
- 4.) KEEP RESCUE EQUIPMENT AVAILABLE.
- 5.) LOCK SAFETY LADDER OR GATE TO PREVENT ENTRY.
- 6.) READ SAFETY INFORMATION SUPPLIED WITH YOUR POOL.



DIAGRAM OF THE CORRECT PLACEMENT OF SAFETY STICKERS IN RELATION TO THE ENTRANCE LADDER.

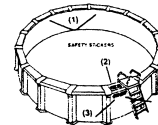

SAFETY STICKERS HAVE BEEN AFFIXED TO YOUR POOL. PLEASE MAKE SURE OF THE PROPER PLACEMENT OF THESE STICKERS IN RELATION TO YOUR ENTRANCE LADDER TO ENSURE THE CORRECT SAFETY WARNING.

IT IS YOUR RESPONSIBILITY AS THE HOMEOWNER TO ENSURE THE CORRECT PLACEMENT OF THE SAFETY STICKERS.

IF YOU DO NOT RECEIVE THE SAFETY STICKERS OR WISH TO OBTAIN ADDITIONAL STICKERS.

PLEASE CONTACT US IMMEDIATELY:



Additional Safety Labels will be supplied AT NO COST to pool owner upon request.



As a pool owner you are responsible for the safety of those who use your above ground pool. We urge you to practice good basic safety habits!

THIS POOL IS DESIGNED FOR SWIMMING AND WADING ONLY. NO DIVING OR JUMPING INTO THIS POOL!

- ⚠ Never use alcohol or drugs when using pool.
- ⚠ Never allow children or non-swimmers in pool area without supervision.
- ⚠ Do not sit, stand or walk on the top seat.
- ⚠ Provide fencing or an enclosure for your pool consistent with local regulations. Consult your dealer for more information.
- ⚠ Always protect pool from entry when pool is not in use.
- ⚠ Keep electric appliances away from pool area.
- ⚠ Do not swim when there is a risk of lightning or electrical storms.
- ⚠ Keep basic rescue equipment at pool-side:
 - Light, strong pole approximately 12 ft. long with safety hook
 - Life preserver ring with throwing rope
 - Emergency phone with emergency phone numbers (police, ambulance, etc.)

POOL SITE SELECTION

DO NOT!

- ⚠ ...Build over or under power lines.
- ⚠ ...Fill pool area in to make level.
- ⚠ ...Build over septic tank or field lines.
- ⚠ ...Choose a site that is soft or sandy.
- ⚠ ...Erect pool in a drainage area or a place that is wet and swampy.



IMPORTANT: Do not erect pool on a site that has previously been treated with any petroleum-based chemical weed killer which might damage your liner. Check with your dealer about the possible need to treat your site with a non-petroleum based weed killer to control nut grass or other persistent weeds. Do not locate pool over sand, gravel, grass, asphalt, tar paper, blacktop surfaces, wood, or any oil-based compounds. We recommend a ground cover under entire pool liner to protect it from soil abrasion.



CORRECT!

Choose a site that is flat and level, with solid, undisturbed ground!

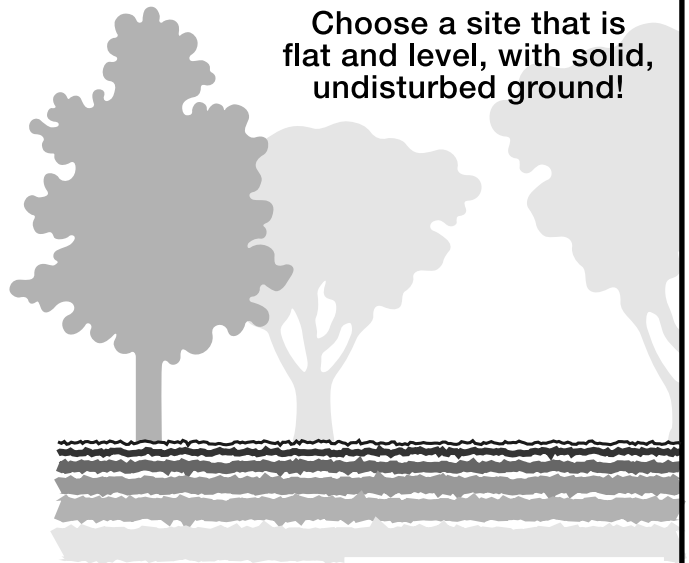

KEY INSTALLATION NOTES



DO NOT attempt installation on a windy day.

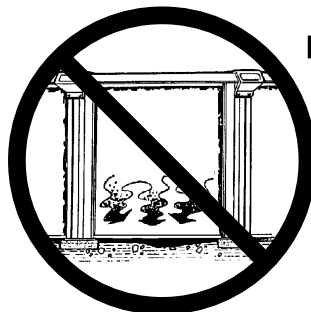

DO NOT allow bottom rims to sag. (NO FILL)

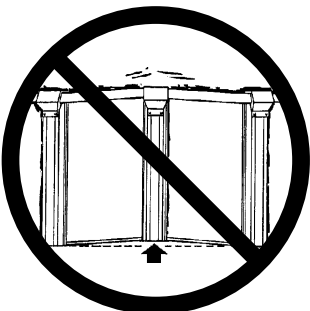

DO NOT allow uprights to become unlevel.



DO NOT backfill against pool wall.

DO NOT WORK ALONE - have at least 2 helpers!

CHECK ROUNDNESS!

Do not allow pool to become more than 1 1/2" out of round!
RECHECK OFTEN!

CORRECT!

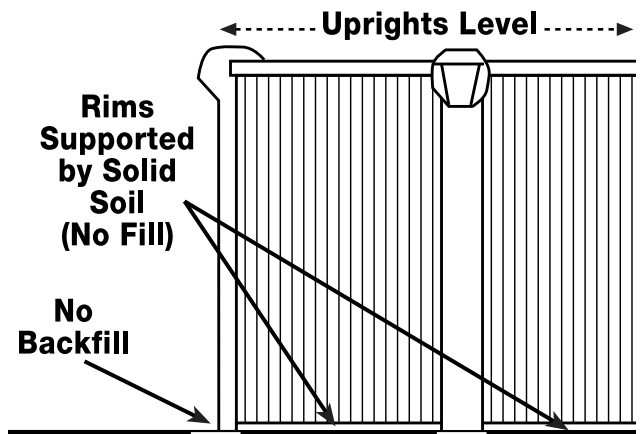

INSTALLATION STEPS

	PAGE
Bottom Material & Liner Selection	5-6
1 Ground Preparation	6
2 Base Plate Positioning	7
3 Bottom Rim Assembly	8
4 Upright Assembly	9
5 Pool Wall Assembly	9-11
6 Bottom Preparation	11
7 Vinyl Liner Installation & Top Rim/Top Plate Installation	12-13
8 Seat Assembly	13
9 Seat Clamp Installation	14
Winterizing Procedures	15
Maintenance Notes	16

TOOLS & MATERIALS

TOOLS

- 35' tape measure
- Carpenter's Level/string level or a transit
- Flat-end shovel
- Garden rake
- Roller, if available, or tamper
- Hammer
- 5/16" hex nut driver
- 7/16" wrench and/or socket
- Large flathead screwdriver
- Phillips head screwdriver

MATERIALS

- Wooden stake
 - Ball of string
 - Can of spray paint
 - Roll of 2" duct tape
 - 2"x4" board, 2' longer than your pool's radius
 - 8"x8"x2" patio blocks (optional – see chart below)
- Important Note: If your pool has Deluxe or Standard Boots (see picture page 7) use 12"x12"x2" patio blocks!**
- Masonry sand or other bottom material
(ask your dealer for the correct amount for minimum 2" base)

Pool Size	Qty. Blocks	Pool Size	Qty. Blocks
12'	10	24'	17
15'	11	27'	19
18'	13	30'	21
21'	15	33'	23

BOTTOM MATERIAL & LINER SELECTION

One of the most important issues you must address before beginning the installation of your pool is the proper selection and matching of the liner, the cove, and the bottom material.

The bottom material must protect your liner from punctures, while the cove prevents the liner from being forced out underneath the bottom rim. To prevent the liner from being forced out underneath the bottom of the wall, the installation must feature a proper cove. If a proper bottom material and cove are not used, it can lead to total liner and pool failure, and this is not covered by the warranty.

There are a number of different acceptable materials available for the bottom and cove of an above ground pool. The most common bottom material used in the industry is a 2" layer of sand along with a 6" to 8" cove made of sand or pre-manufactured material. Many liners are sized with these two factors as a part of their dimensions.

Other bottom materials are available, but many of them are not as thick as sand. During any liner installation, you must ensure that the liner does not exert undue downward pressure on the top of the wall as it fills with water. This is especially important to keep in mind if you have a beaded or a J-hook liner, because the liner wall height is not adjustable as it is with an overlap liner. Before installing your pool, you must verify that the liner and the bottom material are compatible.

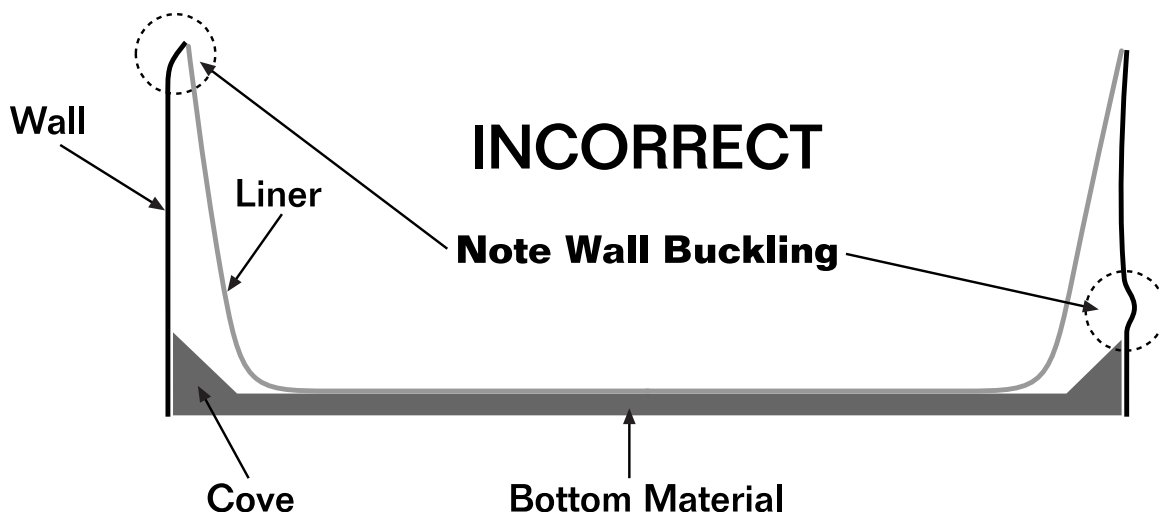
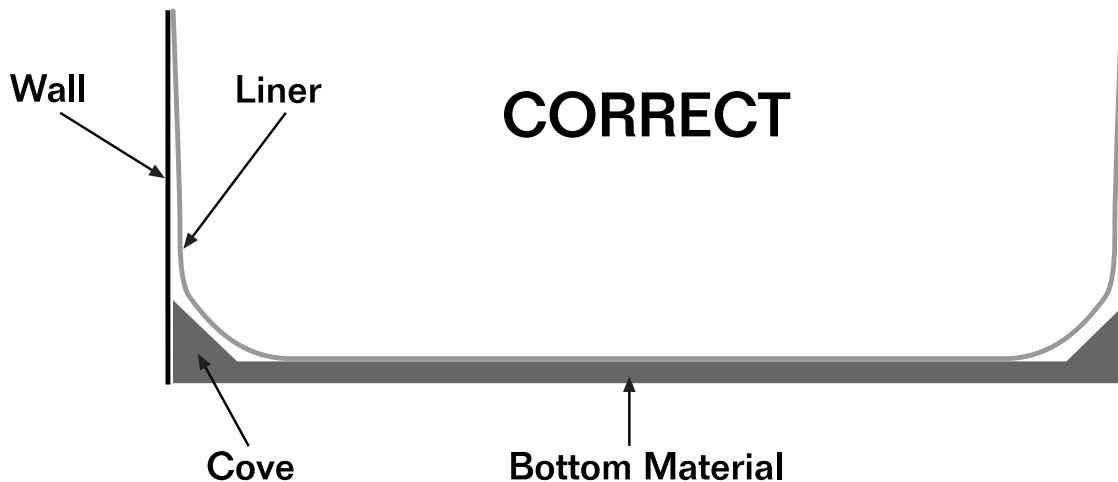

BOTTOM MATERIAL & LINER SELECTION continued from Page 5

During the installation of the liner, you may notice that the liner does not fit the pool perfectly, and there may be some areas where the liner does not contact the bottom, the cove, or the wall at every point. This tendency may be increased if you have a very thin bottom material or a small cove. A small degree of this is desirable, as it reduces the likelihood of wrinkles, and the liner will stretch to fit.

However, if the liner is too small, or if the stretching process places excess pressure on the top of the wall, your wall may buckle, the frame may be pulled inward, or other damage may occur. This is not a manufacturer's defect and it is not covered by the warranty.

Because the pool manufacturer has no control over the selection or installation of the liner, cove or bottom material, it is your responsibility to ensure that the liner, cove, and bottom material you purchase are compatible, and it is your responsibility to ensure that neither the wall or the frame buckle during installation.

Since the most common bottom material is sand, these instructions are for sand. If you use another bottom or cove material, follow instructions provided by the bottom and/or cove manufacturer.



GROUND PREPARATION

Review **POOL SITE SELECTION** on page 3!

STEP 1

1a Drive stake at center point of where you wish pool to be situated. Attach string to center stake. Measure radius of your pool plus 18" on string, and attach marking stick to string. Mark circumference of pool area using spray paint, string and stick.

1b Remove all grass, stones and sticks from marked area. **DO NOT REMOVE CENTER STAKE OR STRING.**

1c Establish lowest point in pool area. Level entire pool site by digging or scraping away uneven areas to the level of the lowest point. **ENTIRE POOL AREA MUST BE ABSOLUTELY LEVEL WITHIN 1 INCH.** Check levelness as shown at left using 2x4 and level. A transit is also very helpful to establish levelness.

Example – 18' Pool:
 $18' \div 2 = 9'$
(diameter) (radius **A**)
Also see chart on Page 7

6

2x4 plank and carpenter's level

18"

Center stake

Do not fill in this area!

Dig earth away to make level.

DO NOT FILL LOW AREAS!

STEP 2 BASE PLATE POSITIONING

This section discusses the use of Patio Blocks to assist in the level installation of your base plates. Patio Blocks are optional, based on the soil conditions in your area. Contact your local dealer for advice on the use of Patio Blocks.

The charts and diagrams show the location of the base plates, and of the optional blocks (if blocks are used). The base plates **MUST** be level, as this is one of the most critical points of the installation. (Example shown is 18' pool.) If blocks are used, scrape away 2" depth of soil from cleared area where each block will rest, centering block on inner "line" (pool circumference). Top of blocks should be flush with soil surface and level with each other and with all patio blocks in every direction around entire pool.

Top of blocks should be level with each other and with all patio blocks in every direction around entire pool.

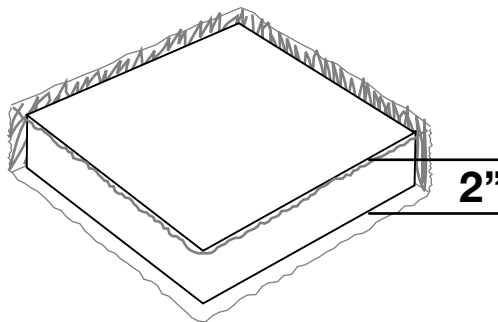
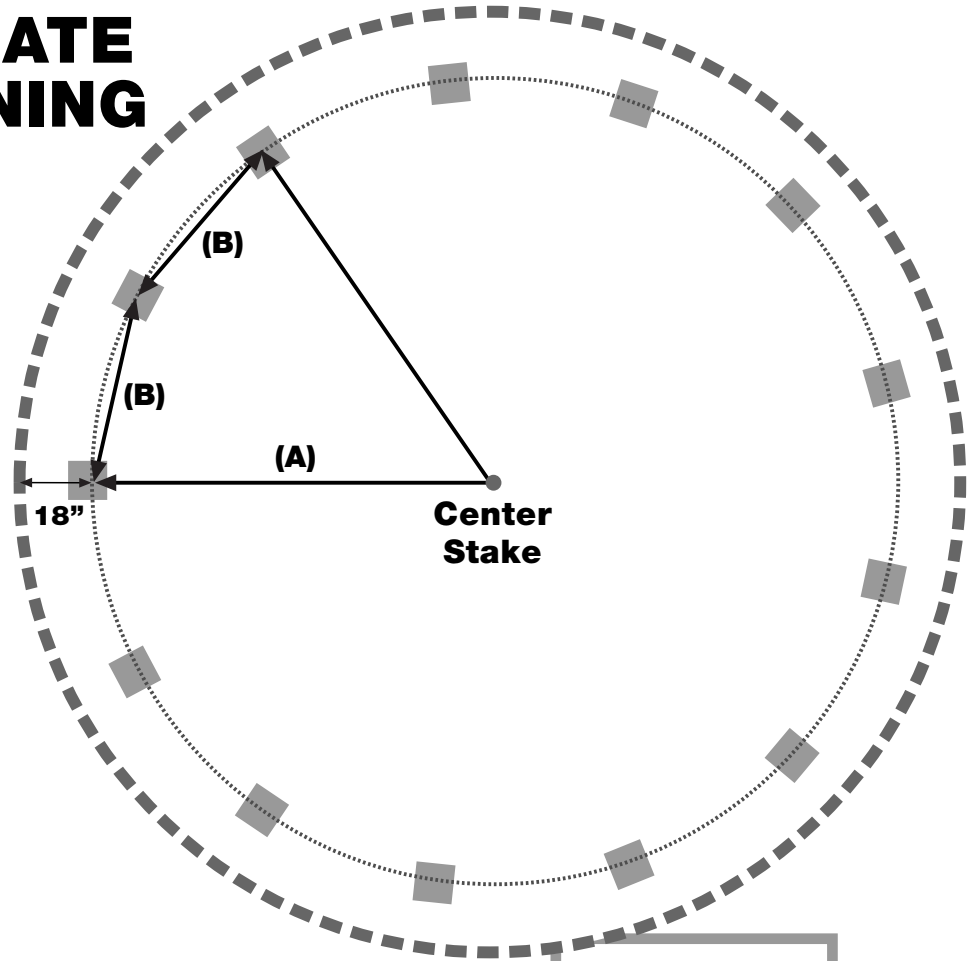

NOTE: If your pool features a Deluxe Base Assembly, you will have a large boot that replaces the base plate.

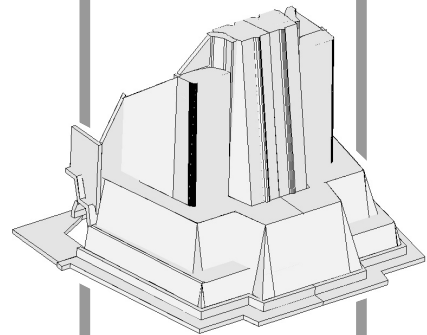

These are the approximate dimensions for locating base plates and optional patio blocks around circumference of pool.

Pool Diameter	12'	15'	18'	21'	24'	27'	30'	33'
A (see diagram above)	6'	7 1/2'	9'	10 1/2'	12'	13 1/2'	15'	16 1/2'
B (see diagram above)	44 1/2"	50 3/4"	51 1/2"	52 1/2"	52 3/4"	53 1/4"	53 5/8"	53 7/8"
Number of Blocks	10	11	13	15	17	19	21	23

STEP 3 BOTTOM RIM ASSEMBLY

3a Move box with pool wall and sand or other material for bottom of pool inside pool area.

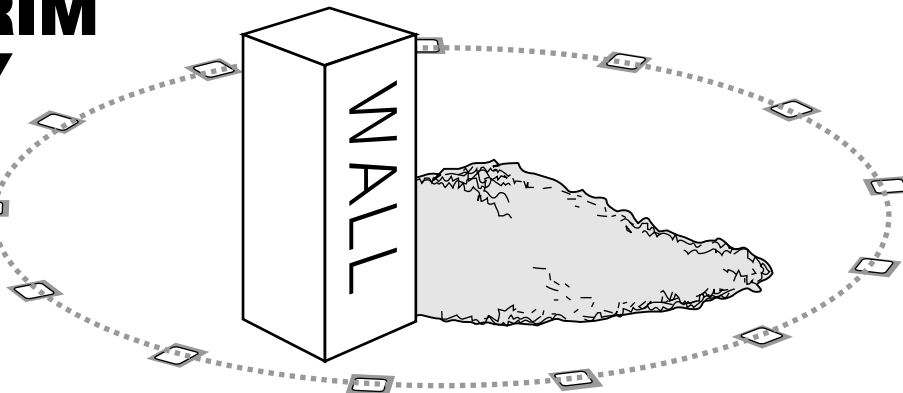

3b Join bottom rims with base plates as shown, placing back of base plate (or boot) at edge of block at inside of pool. Continue around circumference of pool until all base plates are connected with rims.

NOTE: During initial assembly of the rims, you must leave a gap between the rim ends. There are raised ribs inside the base plates that provide some resistance when the rims have been inserted to their proper point.

The proper gap depends on your particular pool Series.

Pool Series	Rim Width	End Gap
6000, 6500, 7000, 7100 & 8000	5/8"	1/2"
8100, 8500 & 9000	1"	3/4"

If your pool features a Deluxe Base Assembly (Expanded Rim), you should also leave a 3/4" end gap. When inserting rims the ends will reach a firm resistance point.

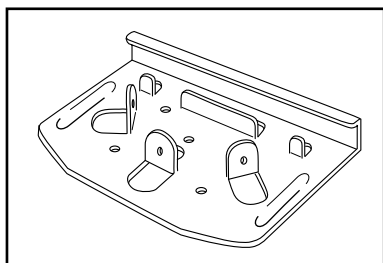
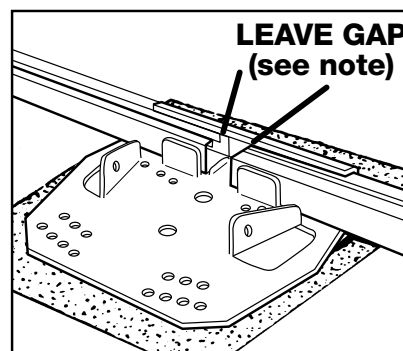

6000 Steel Base Plate

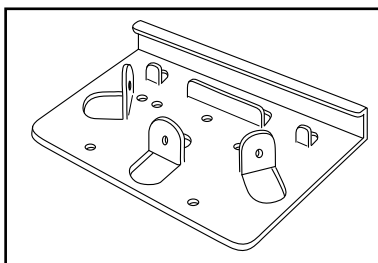

6500 Steel Base Plate

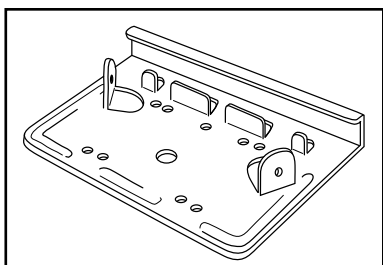

7000, 7100 & 8000 Steel Base Plate

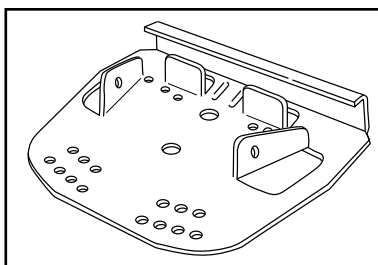

8100, 8500 & 9000 Steel Base Plate

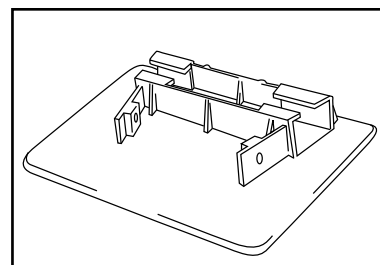

8100, 8500 & 9000 Resin Base Plate

Deluxe Boot & Expanded Rim

Standard Boot & Expanded Rim

If your pool has a Deluxe Integrated Base Assembly with a boot INSTEAD OF base plates, you will also have expanded Rims that should only be used on the bottom of the pool.

CHECK ROUNDNESS!

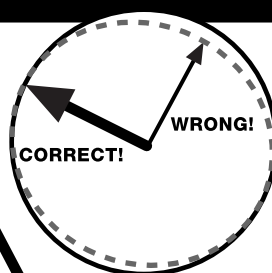

Do not allow pool to become more than 1 1/2" out of round!
RECHECK OFTEN!

STEP 4 UPRIGHT ASSEMBLY

Required Hardware

#10-3/4" Hex Head Screws



NOTE: Clamp assembly not required for 6000 Series.

4a Fasten a clamp base to each upright using (2) 3/4" hex head screws.

SPECIAL NOTE: If your pool clamp bases have two sets of holes, use the top set of holes if you have steel seats and the bottom set if you have resin seats.

4b Arrange the assembled uprights around outside of pool.

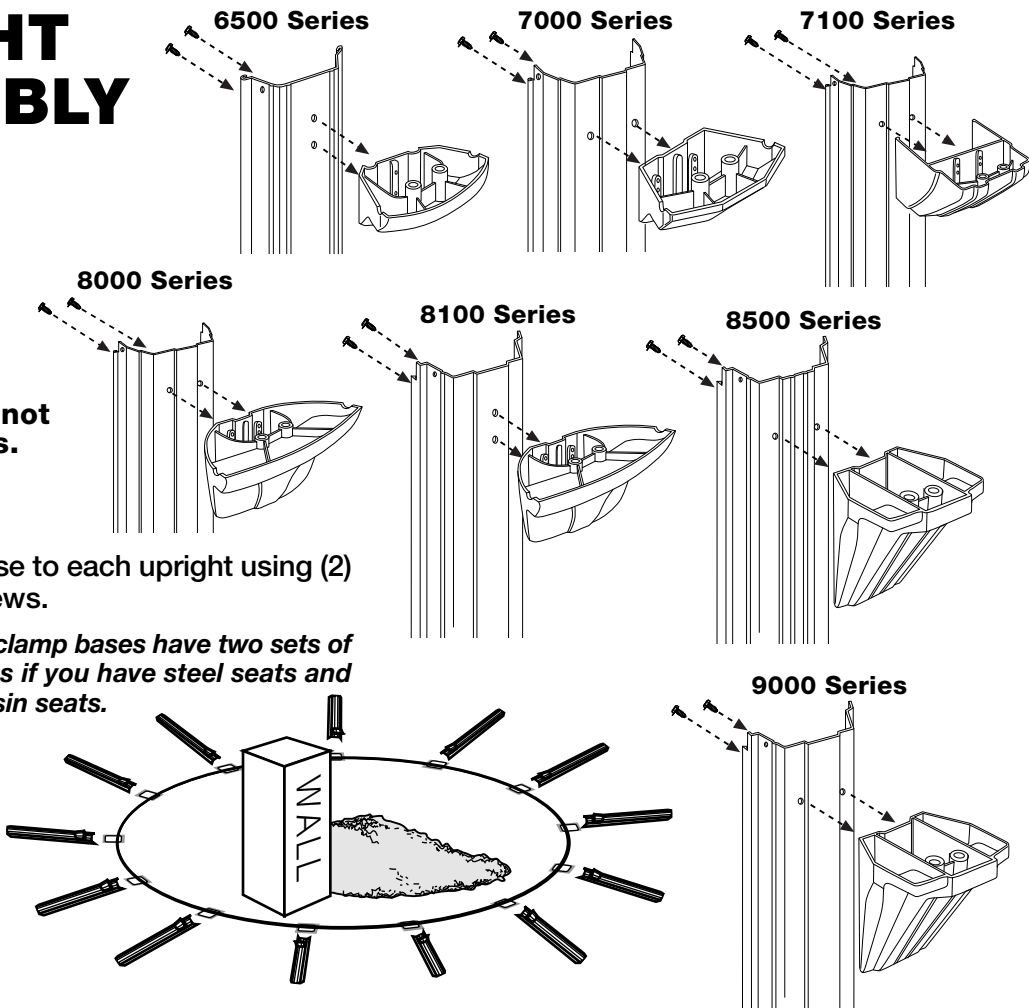

STEP 5 POOL WALL ASSEMBLY

Read this step all the way through carefully before beginning assembly!

DO NOT attempt installation on a windy day.

DO NOT allow wall to kink or buckle.

MAKE SURE you have enough help.



5a Determine where you want to locate the pump and filter. This is where you will begin inserting the pool wall into the rim. Move wall box to that location. Carefully remove pool wall from box.

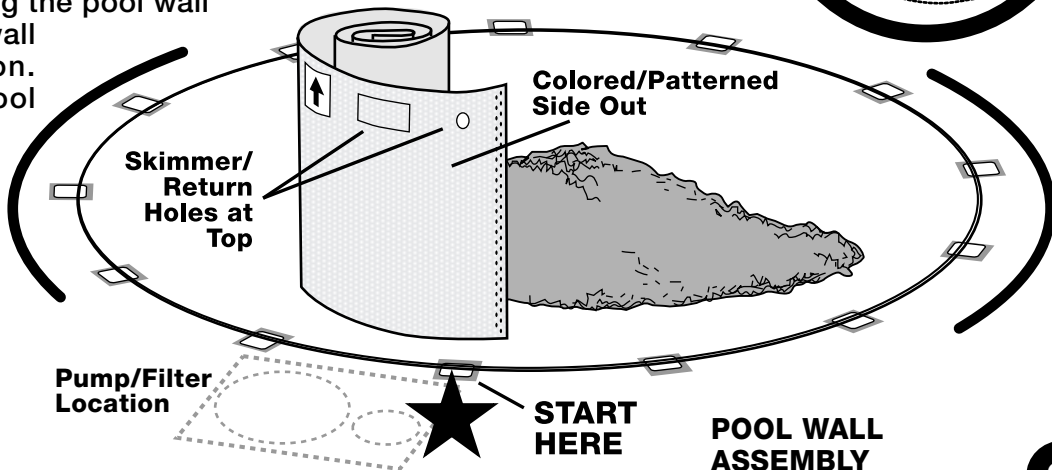

POOL WALL ASSEMBLY
continued on Page 10

POOL WALL ASSEMBLY
continued from Page 9

If your pool does NOT have an Optional Stainless Steel Service Panel, go to Step 5c.

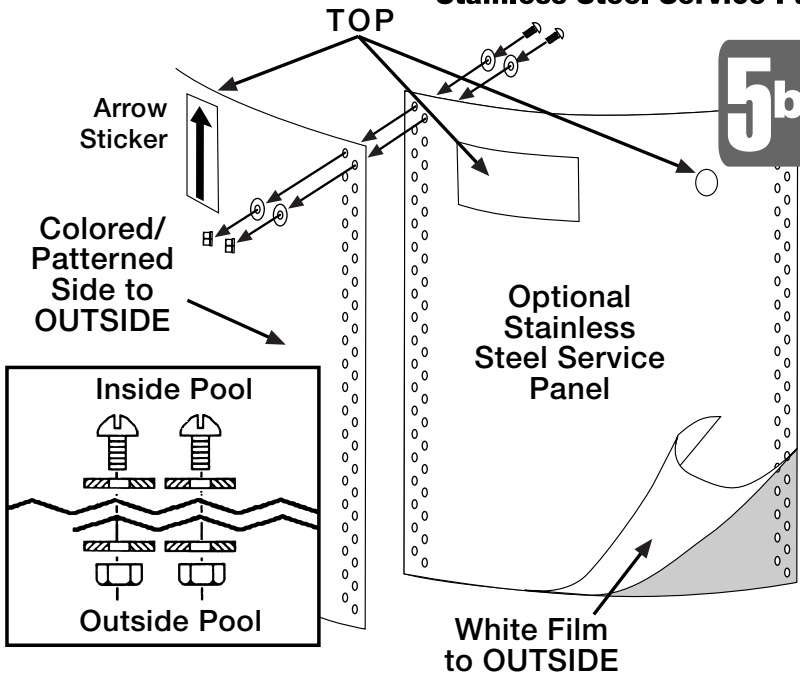

5b

Fasten Service Panel to end of wall as shown. Make sure wall and panel are right side up.

NOTE: When you are attaching Service Panel to wall, "finger tighten" ONLY the bolts, washers and nuts until all are in place. Tighten all nuts and bolts before inserting wall into rims. **DO NOT USE POWER TOOLS AND DO NOT OVER-TIGHTEN BOLTS.**

Do not skip any holes when connecting the wall or the integrity of your pool will be compromised, and pool will collapse when filled with water. If your pool features a Deluxe Expanded Bottom Rim, you may not have access to the bottom hole in the wall to panel joint. It is acceptable to eliminate this bolt. **ALL OTHER BOLTS MUST BE INSTALLED!**

Required Hardware

WALL HARDWARE:
Orange Labeled Package

1/2" Bolts and Nuts (52 each)
Washers (104)

Optional Stainless Steel Service Panel

1/2" Bolts and Nuts (52 each)
Washers (104)

(White film, if present, is for shipping purposes only, and should be removed prior to installation.)

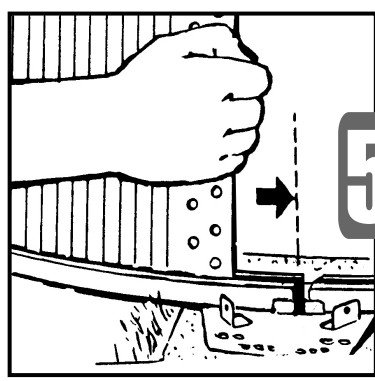

5c

Working clockwise, insert wall into rim, beginning at base plate nearest desired skimmer/filter location.

Required Hardware

#10-3/4" Hex Head Self-Tapping Screws

#14-5/8" Screws (6500 Series ONLY)

#12-1/4" Flat Head Phillips Screws

NOTE: It is very important to begin installing wall with bolt holes centered on base plate. This ensures that wall bolts will not interfere with uprights.

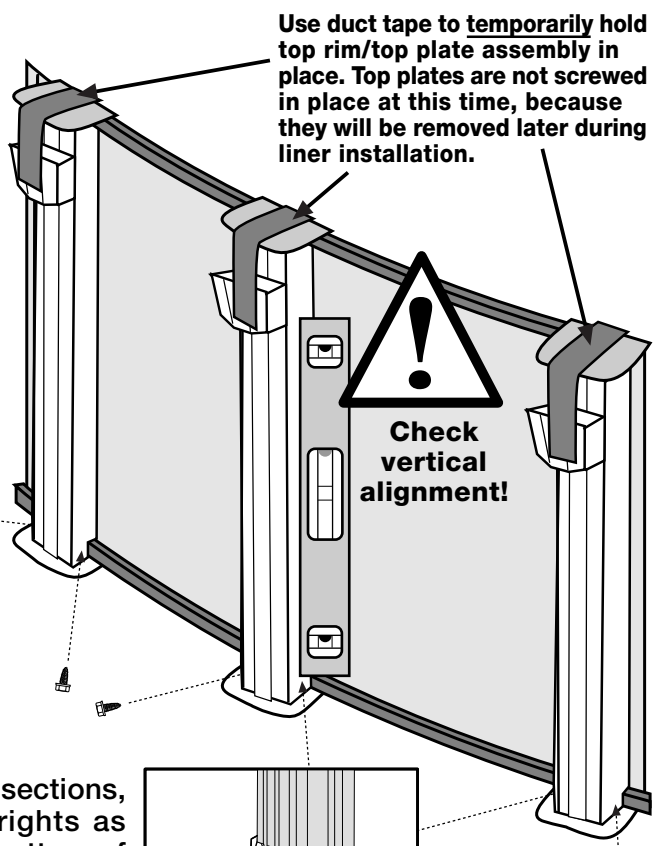

Use duct tape to temporarily hold top rim/top plate assembly in place. Top plates are not screwed in place at this time, because they will be removed later during liner installation.

5d After you have inserted wall into 3 bottom rim sections, stabilize wall with top rims, plates and uprights as shown. Screw (2) 3/4" self-tapping screws at bottom of each upright to hold it in place. (Use #14-5/8" screws for 6500 Series pools.) Use duct tape to temporarily hold top rim/top plate assembly in place.

10 **NOTE:** If your pool features a Deluxe Base Assembly, the uprights slide into the recesses at the top of the boots and are fastened in place by (2) #12-1/4" Phillips screws.

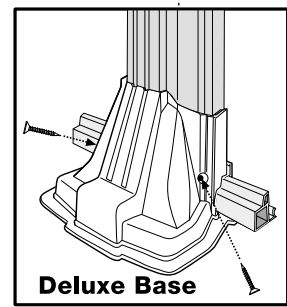

Deluxe Base

SPECIAL NOTE: If you have a beaded liner (see Page 12) you will not remove top rims and top plates during installation of liner. As you install the wall around the circumference of the pool, install the bead receiver over top of wall, then attach top rims and top plates (see instructions on Pages 12 and 13, Step 7b).

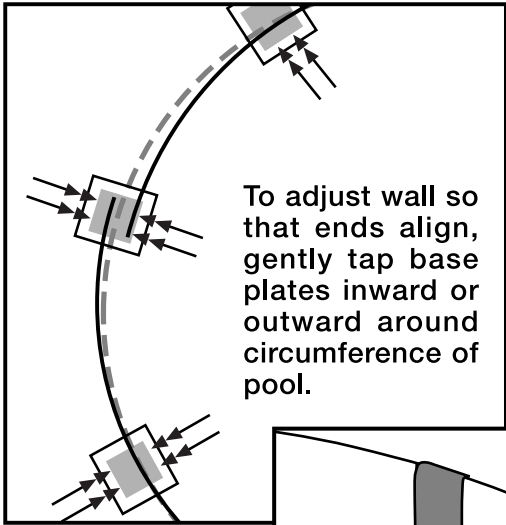

To adjust wall so that ends align, gently tap base plates inward or outward around circumference of pool.

5e

Continue inserting wall and installing uprights several sections at a time until entire wall is installed in bottom rim. Connect ends of wall as shown in **Step 5B**.

Do not skip any holes when connecting the wall or the integrity of your pool will be compromised, and pool will collapse when filled with water. If your pool features a Deluxe Expanded Bottom Rim, you may not have access to the bottom hole in the wall to wall joint. It is acceptable to eliminate this bolt. ALL OTHER BOLTS MUST BE INSTALLED!

5f

Cover wall joint bolts on inside of pool wall with duct tape.

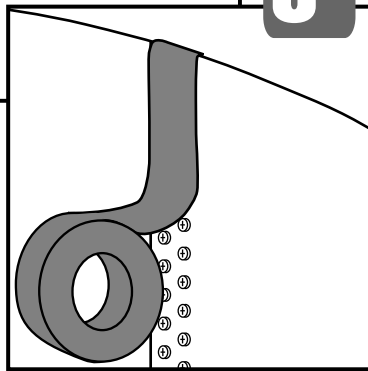

CHECK ROUNDNESS!

Do not allow pool to become more than 1 1/2" out of round! RECHECK OFTEN!



STEP 6 BOTTOM PREPARATION

IMPORTANT: Before you begin Steps 6 and 7, please review the information provided on pages 5 and 6 concerning the selection of bottom material and proper liner fit!

6a Spread 2" layer of sand or other bottom material over entire bottom of pool and tamp or compress well.

6b Make cove as shown around entire inside of pool wall.

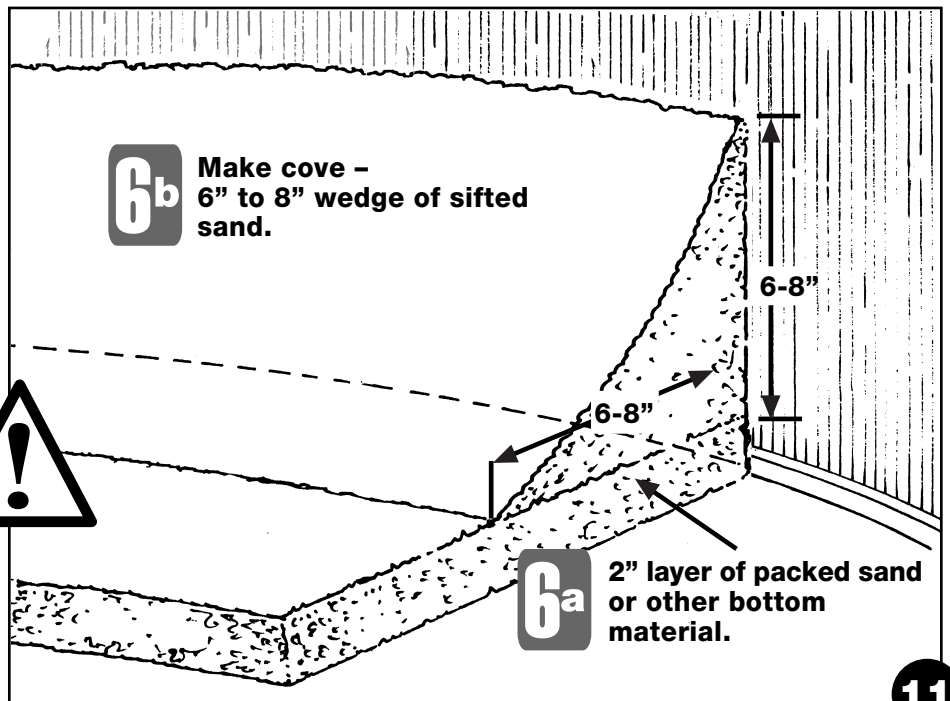

Cove is absolutely essential!

Recheck roundness one final time and remove center stake and string, filling in hole and tamping down sand.

STEP 7

VINYL LINER INSTALLATION & TOP RIM/TOP PLATE INSTALLATION

This section provides general information concerning liner installation. Refer to the installation instructions supplied by your liner manufacturer for more details about installing your liner.

Your liner may be one of three general types:

- **Overlap**

When installing an Overlap liner, you must use the manufacturer-supplied coping strips to hold the liner in place over the wall. The coping is packed in the wall carton.

- **J-Hook (also sometimes called "V-welt")**

When installing a J-hook liner, the liner has a built-in hook that is placed over the top of the wall, and the coping strips are not required.

- **Beaded**

When installing a Beaded liner, you must use bead receiver, **sold separately**. The bead receiver is installed over the top of the wall during wall installation. Again, the coping strips are not used.

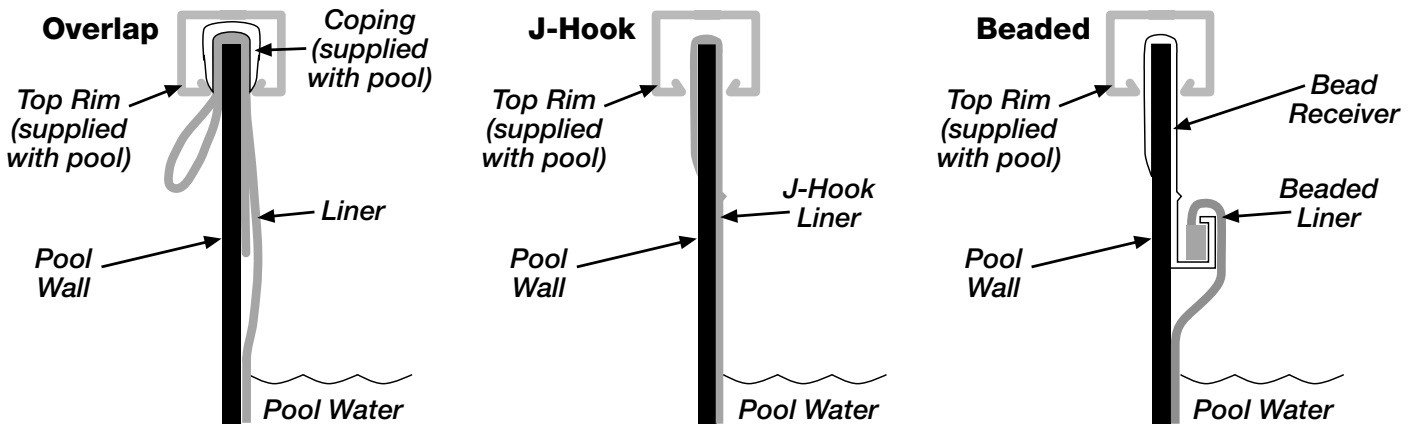

Unfold liner in the center of pool area. Remove your shoes to avoid damage. Carefully open liner so that printed/patterned side is facing upwards. Bring bottom perimeter seam of liner as close as possible to covered rims. Grip seam and carefully pull it right up to the wall all around circumference of pool being careful not to disturb cove. The floor of the liner will now be approximately in its final location, with the side walls of liner resting on pool bottom.

7a Next, carefully lift up three sections of rims, together with the top plate, from pool wall.

7a Overlap Liner

For best appearance, pull the liner up until bottom seam is approximately one inch off bottom of pool. Then fold the edge of the liner under itself and pull the folded edge over the wall as shown. When you have folded the liner correctly, approximately 2 1/2" will overhang the wall. Secure the liner section with pieces of plastic coping (packed inside wall carton).

J-Hook Liner

If you have a J-hook liner, the general assembly is the same. However, instead of folding the liner over the wall and securing it with the coping, simply position the liner's J-hook over the top of the pool wall (see above).

Beaded Liner

If you have a beaded liner, instead of folding the liner over the top of the wall, insert the liner bead into the bead receiver that was installed during **Step 5d**.

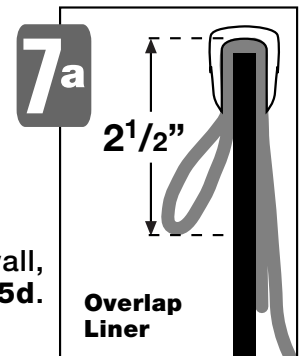

Required Hardware

#10-3/4" Hex Head Self-Tapping Screws



#14-5/8" Screws (6500 Series ONLY)



#10-1 1/4" Hex Head Self-Tapping Screws

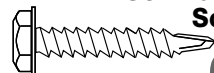

7b

After you have secured the liner to several sections of wall, install the top rims and top plates as shown. As each top plate and rim section is installed, fasten top plates to uprights using (2) 3/4" hex head self-tapping screws per upright. (Use #14-5/8" screws for 6500 Series pools.) **NOTE: If your pool features a Deluxe Base Assembly, use (2) #10-1 1/4" self-tapping hex head screws to attach the top plate to the upright.** Continue working your way around the pool until entire liner is in place, and all rims and top plates are installed.

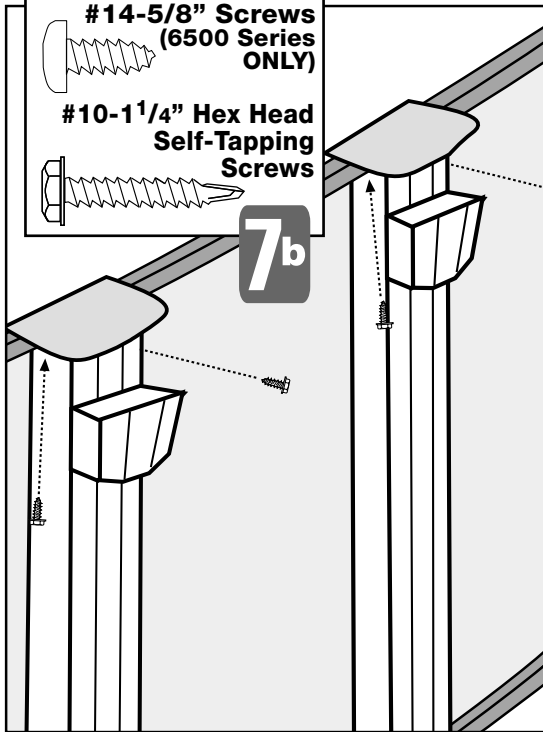

Slowly begin to fill pool to a depth of one to two inches. This will firmly secure the bottom of the liner in its final position. Use a slow stream of water. This will keep your liner smooth during the accumulation of the critical first two inches of water. Watch the water level carefully. If water collects in one spot, your pool foundation is not level. The water must be level within one and one quarter inch. Once you have started to fill the pool, do not try to pull the liner forcefully. The weight of even one half inch of water will make it difficult to move the liner without damaging it.

Make sure that seams on the bottom and side of the liner are straight. Neatly reduce surplus on bottom of liner by smoothing out any wrinkles in the direction of the wall. Pull liner firmly but gently, avoiding sharp tugs and pulling the liner by the seams. Be careful not to disturb the cove at the base of the wall.

Overlap Liner Installation Only: Equally distribute any excess in the liner circumference around the top of the pool. Place any excess between the plastic coping strips that secure the liner to the wall by carefully removing top rim and top plate, adjusting liner, and then reattaching rim and plate.

STEP

8

SEAT ASSEMBLY

Required Hardware

#10-3/4" Hex Head Self-Tapping Screws (4 per seat)



#14-5/8" Screws (6500 Series ONLY)

8a

Check (B) measurement (see Page 7) for proper spacing of top seats. Also, recheck vertical alignment of uprights.

X - Optimal Safety Sticker Placement

8b

Arrange seats around perimeter of pool, noting optimal safety sticker placement.

Deeper "flange" on seat faces to outside of pool. Do not fasten seats at this time.

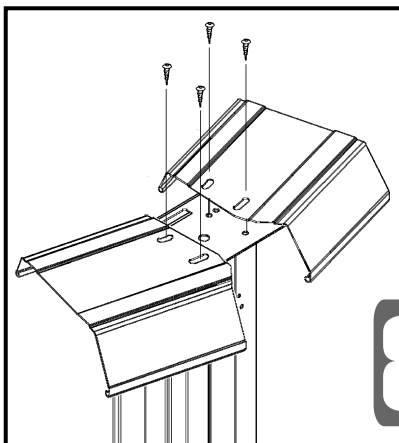
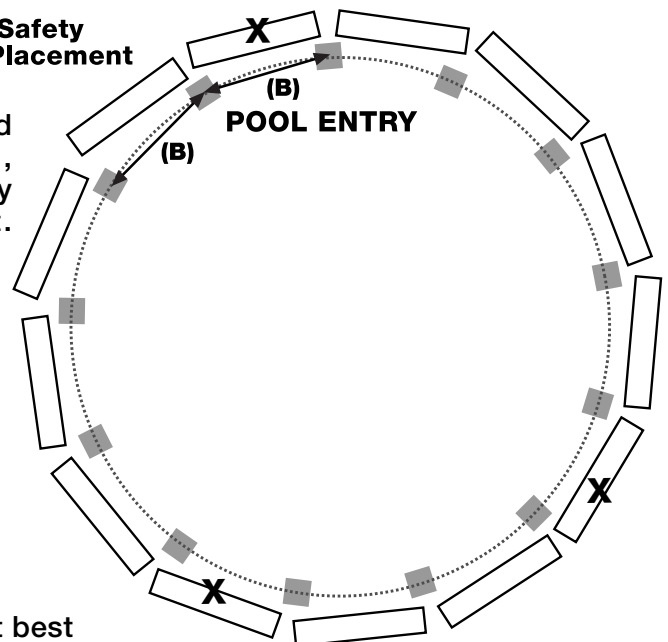

8c

Choose holes that best center seat between 2 adjacent top plates. Fasten each end of seat to top plates as shown.

STEP 9 SEAT CLAMP INSTALLATION

Required Hardware

#10-3/4" Hex Head Screws

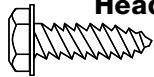

8000 & 8100 SERIES

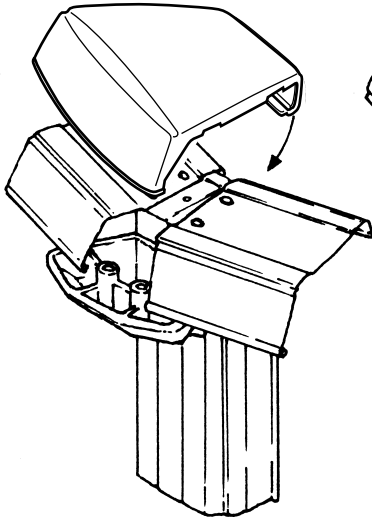

7100 SERIES: Position seat clamp so that it is centered over joint between seats. Hook top piece of seat clamp under inside rim of pool top seat (see 8000 Series diagram below). Rotate the top piece over the seat until it makes contact with the seat clamp base, and protruding ridges on seat clamp and clamp base align. (See figure at right) Attach seat clamp to seat base with 3/4" hex head screw. Insert the decorative tab cover into three slots in top of seat clamp and insert bottom tab under seat clamp to cover screw.

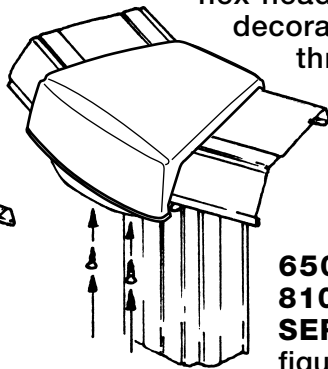

6500, 7000, 8000, 8100, 8500 & 9000 SERIES: Referring to figures at left, position

seat clamp so that it is centered over joint between seats. Hook top piece of seat clamp under inside rim of pool top seat. Rotate the top piece over the seat until it makes contact with the seat clamp base, and screw posts are inserted correctly into post receivers in clamp base. Assemble the seat clamp top to base using (2) 3/4" hex head screws. **NOTE: Not required for 6000 Series.**

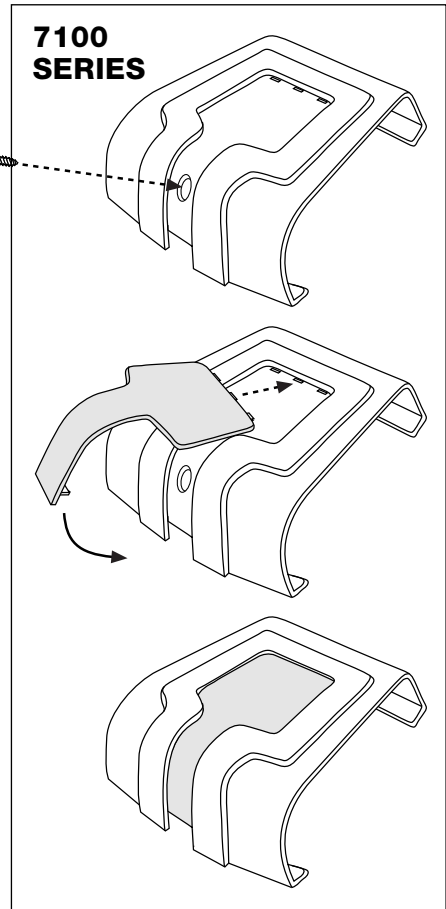

6000 SERIES

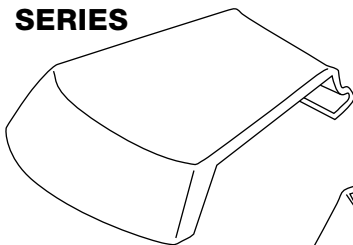

8500 SERIES

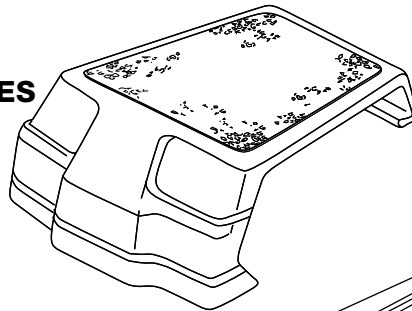

6500 SERIES

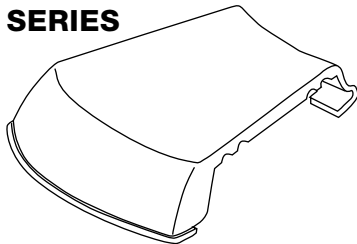

7000 SERIES

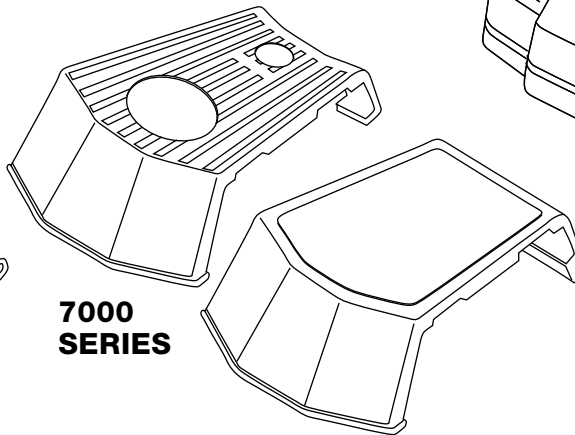

9000 SERIES

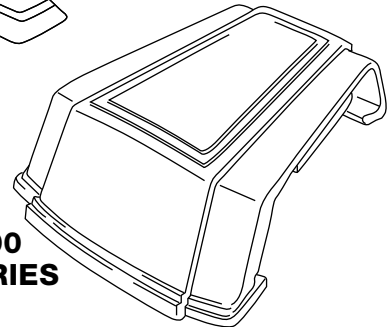

This completes installation of your new above ground pool!

Consult your dealer for instructions on proper installation of the skimmer, return, pump, and filter.

WINTERIZING PROCEDURES

Please consult your local dealer for winterizing advice for your particular area.

Because pools are installed in widely varied geographical areas, and under varying climatic conditions, firm statements and warranties concerning winter care cannot be given. If the winters in your area are severe, it may be advisable to dismantle your pool – consult your local dealer. Heavy winds, ice, snow, sleet, etc. can cause damage even though this product has been made to withstand average winter conditions and you have taken all winterizing precautions detailed below and on the following page. Accordingly, you must use your own judgment to determine the wisdom of leaving your pool up through the winter. We cannot assume any responsibility for pool failure which might result from winter hazards, or from misuse or neglect.

1. Check all framework for proper fit. Tighten any loose nuts and bolts. Touch up painted parts.
2. Check the pool wall for misalignment and deterioration, correct and touch up where necessary.
3. Check that top of liner is properly seated on wall.
4. Backwash filter for 3 or 4 minutes to remove all dirt, and clean the pool, if your filter has this feature.
5. Remove all pool accessories from the pool such as inpool ladders, slides and over the wall skimmer.
6. If you have an in-wall skimmer, remove all parts from skimmer. Refer to your *Skimmer Instruction Guide* for proper winterizing instructions. Do not leave an empty pool standing. **WATER LEVEL IN POOL SHOULD BE BELOW POOL RETURN FITTING.** Water or ice must not be allowed to collect in skimmer housing.
7. Disconnect filter and other apparatus from the pool. Refer to your *Filter Instruction Guide* for winterizing your filter. Never store pump in an unheated shed or garage where temperature is likely to fall below freezing.
8. Balance the pH level of the pool water and sterilize. Use 4 to 5 times the daily usage for chlorine. **DO NOT ADD LOOSE CHLORINE TO WATER, AS THIS MAY BLEACH AND EVENTUALLY ROT YOUR LINER OR DAMAGE POOL FRAMEWORK.** Agitate the water thoroughly when adding chlorine and spread evenly over pool surface.
9. **A pool cover is strongly recommended** as a sound investment for the protection and long life of your pool. The purpose of a pool cover is to prevent leaves and debris from entering the pool and more important, to block out sunlight so that algae will not grow. Use either a solid material cover or one with a very close mesh to keep out dirt during the winter. Note that none of these covers are designed to withstand an unsupported load of snow or ice. Your cover should float on the water so that pressures are equalized and very little force is placed upon the tie-down grommets. **The use of an inflated pressure compensator under the cover is strongly recommended.** When floating in the water, it supports the cover. When the water freezes, these compensators bear some of the ice pressure which results.

If your pool has been properly covered for the winter, the cover will be fully supported by the water underneath, and there will be little, if any, downward pressure exerted on the frame by either the cover or the method you use to support the cover. **Attaching heavy weights to the cover and suspending the weights from the top seats can cause damage to the seats, especially when combined with hot sun on a dark cover. This is not a manufacturer's defect and it is not covered by the warranty.**

IMPORTANT WINTER RULES

After pool has been winterized and ALL steps carefully followed, the following checks and procedures MUST be strictly followed during fall, winter and spring seasons. **YOUR POOL AND EQUIPMENT WARRANTY WILL BE INVALID IF POOL HAS BEEN IMPROPERLY WINTERIZED AND THE FOLLOWING PROCEDURES NOT STRICTLY ADHERED TO. POOLS WHICH HAVE BEEN INCORRECTLY WINTERIZED AND CARED FOR DURING THE SUMMER AND WINTER HAVE BEEN KNOWN TO COLLAPSE UNDER THE TREMENDOUS PRESSURES EXERTED BY ICE AND SNOW AND YOU HAVE NO RECOURSE AGAINST THE DEALER OR MANUFACTURER.**

1. A pool that is left up during freezing water temperatures **MUST NOT BE ALLOWED TO LEAK.** To determine if your pool is leaking, mark the liner at the water level and **VERY CLOSELY** observe the water level in pool for a period of 10 days to 2 weeks after pool is closed for the season. Any rain during this period may compensate for undetected water leakage. Therefore, observation period must be extended to find any leaks. **ALL LEAKS MUST BE FOUND AND IMMEDIATELY REPAIRED.** Any water leakage which is undetected or occurs after top surface is frozen will allow the frozen surface to settle and may damage the pool liner, wall and framework. **NOTE:** It is not uncommon for a leak to develop during rigorous summer usage and go undetected. What is thought to be water loss due to evaporation or spillage may be caused by a small leak. Persistent wet or damp areas around pool should be inspected.
2. Maintain a strict leak inspection schedule throughout the fall, winter and spring months. **IF WATER IS ALLOWED TO LEAK OUT FROM UNDER THE ICE DURING THE WINTER, YOUR POOL MAY BE SEVERELY DAMAGED.** The following can happen because of leakage or improper winterization:
 - A. Unsupported ice can collapse, tearing liner, wall and framework.
 - B. Undetected leakage can undermine pool foundation resulting in pool collapse.
3. Be sure that the in-wall skimmer is free of debris and ice and that **WATER LEVEL IN POOL IS BELOW INLET AND SKIMMER OPENINGS. WATER SHOULD NOT BE ALLOWED TO BUILD UP OR COLLECT IN SKIMMER HOUSING – IT WILL FREEZE AND CRACK.**
4. Do not permit anyone on top of the cover at any time, whether or not the water is frozen.

MAINTENANCE NOTES

- Your pool needs care. The purity of the water must be maintained by using a chlorine-type purifying chemical. Carefully follow the instructions supplied with your particular chemicals.
- A foot bath, adjacent to pool entry area, is desirable to wash off dirt, leaves and grass before entering pool.
- Touch up all scratches on pool wall and frame with color matched enamel paint available at most paint, hardware, auto stores or your pool dealer. **Keep your pool wall and frame clean.** Wash periodically with a mild soap (no abrasives). Quickly wash away pool chemical deposits on pool frame.

The following maintenance is required in high corrosion areas where seashore salt-water is present. Use clear non-yellowing household or auto wax on metal parts. Coat all exposed screw and bolt heads with clear outdoor varnish or matching paint.

- **NOTE:** Never leave an empty pool standing for even a short period of time.

AN IMPORTANT WORD ABOUT YOUR POOL WALL:

- Occasionally steel or aluminum pool walls may show evidence of corrosion. This condition can appear anywhere on the wall and may be due to such factors as local environment, pool chemical spillage, a leaking skimmer or inlet fitting, or actual accidental physical damage or abuse. **YOU SHOULD MAINTAIN A STRICT PERIODIC POOL WALL INSPECTION SCHEDULE.** If any corrosion is found, **IMMEDIATE CORRECTIVE ACTION MUST BE TAKEN. IF THE CORROSION PERSISTS THE WALL MUST BE REPLACED.**
- Tighten and seal around your skimmer and inlet if corrosion appears in these areas. Carefully wire brush away all loose material on all affected areas of wall. Apply a coat of anti-rust enamel primer and let dry. Follow primer coat with a coat of color matching anti-rust enamel paint. **CONTINUE TO INSPECT ALL AREAS.**

Protect yourself and all users of this pool by making sure that Safety Stickers affixed to your pool are displayed in accordance with the manufacturer's instructions!

We have provided warning labels to assist you in preventing diving and/or jumping into your pool. Should you need additional labels for any reason, we will supply these labels to you free of charge at your request. Simply order the desired label from us.

In your Homeowner's Package, we have provided the book **"The Sensible Way to Enjoy Your Pool"**, published by the Association of Pool & Spa Professionals. Additional consumer awareness booklets (listed below) are available from the APSP.

FOR YOUR RECORDS

For future use, it is advisable that you write down some information pertaining to the model of the pool you have purchased. If you are unsure of the Model Name, Series Number, etc., contact your local dealer immediately to acquire the information needed. When making a warranty claim or just purchasing replacement parts, it is necessary to know the following information.

Purchase Date: _____

Dealer Name: _____

Dealer Phone Number: _____

Pool Series Number: _____

Model Name: _____

Pool Size: _____ Wall: 48" 52" 54"

Wall Version: Classic Ultra (SSPanel)

- **"Children Aren't Waterproof"**, published by APSP
- **"Pool & Spa Emergency Procedures for Infants and Children"**, published by APSP

Contact:

Association of Pool
& Spa Professionals
2111 Eisenhower Avenue
Alexandria, VA 22314
(703) 838-0083

1601 Wicomico Street
Baltimore, Maryland 21230
(410) 547-7303