

# MLS SHOOTOUT TABLETOP ROD SOCCER TABLE ASSEMBLY INSTRUCTIONS



NG1026

**THANK YOU!**













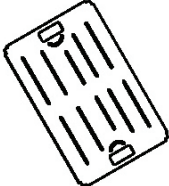
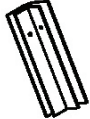
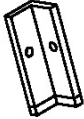
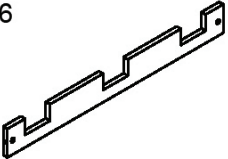
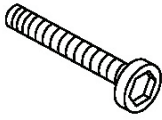

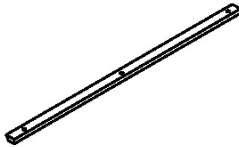

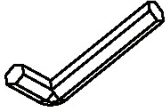

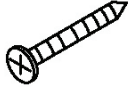
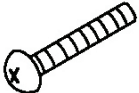
Thank you for your purchase of our product.

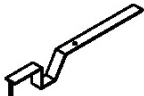
We work around the clock and around the globe to ensure that our products maintain the highest possible quality. However, in the rare instance that your product is defective or missing parts, contact Challenger Manufacturing at 800-759-0977 to submit parts requests or warranty claims. Please read the warranty information at the back of these assembly instructions for further details.

**IMPORTANT! PLEASE READ THESE ASSEMBLY INSTRUCTIONS IN ENTIRETY BEFORE ASSEMBLING YOUR PRODUCT.**

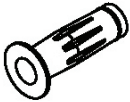
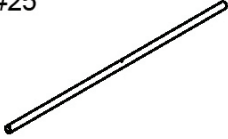







# PARTS IDENTIFIER (NOT TO SCALE)

<p>#1</p>  <p><b>SIDE PANEL</b> 2 pcs</p>	<p>#2</p>  <p><b>END PANEL</b> 2 pcs</p>	<p>#3</p>  <p><b>PLAYFIELD</b> 1 pc</p>	<p>#4</p>  <p><b>CORNER</b> 4 pcs</p>	<p>#5</p>  <p><b>LEG</b> 4 pcs</p>
<p>#6</p>  <p><b>PLAYFIELD SUPPORT BRACE</b> 1 pc</p>	<p>#7</p>  <p><b>5/16" BOLT</b> 8 pcs</p>	<p>#8</p>  <p><b>FLAT WASHER</b> 8 pcs</p>	<p>#9</p>  <p><b>PLAYFIELD BORDER</b> 2 pcs</p>	<p>#10</p>  <p><b>WRENCH</b> 1 pc</p>
<p>#11</p>  <p><b>HEX WRENCH</b> 1 pc</p>	<p>#12</p>  <p><b>1/2" FLAT SCREW</b> 4 pcs</p>	<p>#13</p>  <p><b>1/2" ROUND SCREW</b> 38 pcs</p>	<p>#14</p>  <p><b>1" FLAT SCREW</b> 2 pcs</p>	<p>#15</p>  <p><b>3/4" BOLT</b> 2 pcs</p>
<p>#16</p>  <p><b>NUT</b> 8 pcs</p>	<p>#17</p>  <p><b>PLAYER CONTROL GEAR</b> 16 pcs</p>	<p>#18</p>  <p><b>GOALIE CONTROL ARM</b> 16 pcs</p>	<p>#19</p>  <p><b>SOCCER GOAL</b> 4 pcs</p>	<p>#20 #20B</p>  <p>#20A - RIGHT GOAL BORDER #20B - LEFT GOAL BORDER 2 pcs ea.</p>
<p>#21</p>  <p><b>ROD STOPPER</b> 10 pcs</p>	<p>#22</p>  <p><b>BALL RETURN BOX</b> 2 pcs</p>	<p>#23</p>  <p><b>ROD BUSHING</b> 10 pcs</p>	<p>#24</p>  <p><b>HAND GRIP</b> 10 pcs</p>	<p>#25</p>  <p><b>LONG PLAYER ROD</b> 4 pcs</p>
<p>#26</p>  <p><b>MEDIUM PLAYER ROD</b> 2 pcs</p>	<p>#27</p>  <p><b>SHORT PLAYER ROD</b> 4 pcs</p>	<p>#28</p>  <p><b>BLUE PLAYER</b> 5 pcs</p>	<p>#29</p>  <p><b>YELLOW GOALIE</b> 1 pc</p>	<p>#30</p>  <p><b>GREEN PLAYER</b> 5 pcs</p>

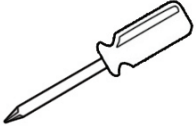

# PARTS IDENTIFIER (NOT TO SCALE)

<p>#31</p>  <p><b>RED GOALIE</b> 1 pc</p>	<p>#32</p>  <p><b>SOCCER BALL</b> 2 pcs</p>	<p>#33</p>  <p><b>1/4" ROUND SCREW</b> 20 pcs</p>	<p>#34</p>  <p><b>CORNER CAP</b> 4 pcs</p>	<p>#35</p>  <p><b>MANUAL SCORER</b> 2 pcs</p>
<p>#36</p>  <p><b>LEG LEVELER</b> 4 pcs</p>	<p>ADDITIONAL EQUIPMENT REQUIRED:</p>  <p><b>PHILLIPS HEAD SCREWDRIVER</b></p>			



## ASSEMBLY TIPS

1. Find a clean, level surface to begin the assembly of your game table. The table will be partially assembled upside down and then turned over onto its legs.
2. Remove all of the contents from box and verify that you have all of the parts shown on the Parts Identifier before you begin assembly. **Note: Some parts may be pre-installed or pre-assembled.**
3. Some figures or drawings may not look exactly like your product. Please read and understand the text before beginning each assembly step.
4. When installing parts that have more than one screw or bolt, hand tighten all screws or bolts in place before finishing tightening with screwdriver or hex wrench.
5. Electric screwdrivers may be helpful during assembly; however, please set a low torque and use extreme caution because screws may be stripped or overtightened if the electric screwdriver's torque is set too high.

### **WARNINGS!**

READ AND FOLLOW ALL ASSEMBLY, OPERATION AND SAFETY INSTRUCTIONS CAREFULLY.

CHOKER HAZARD - THIS TABLE CONTAINS SMALL BALLS AND PARTS - NOT SUITABLE FOR CHILDREN UNDER 3 YEARS OF AGE.

# ASSEMBLY INSTRUCTIONS



1. Attach one END PANEL #2 to each SIDE PANEL #1 with CORNER #4 and 1/2" ROUND SCREW #13. *Note: The table is assembled upside down.*

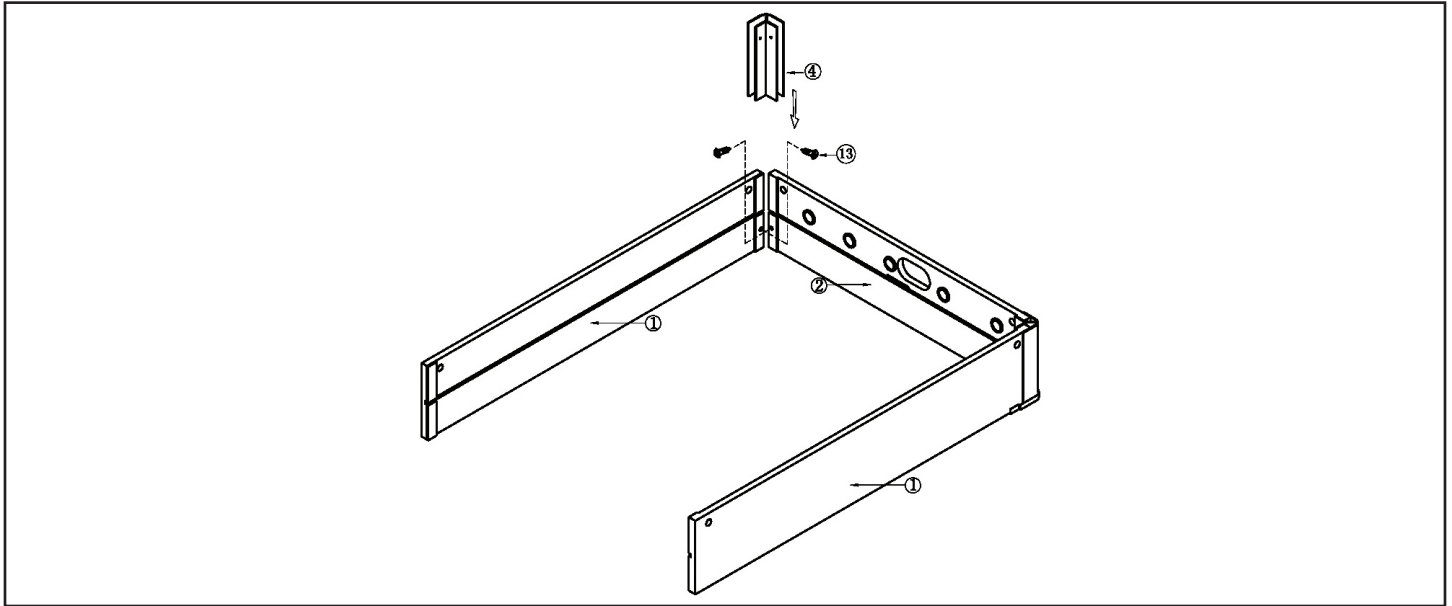

2. Slide PLAYFIELD #3 with field markings facing down into the SIDE PANEL grooves.

3. Attach remaining END PANEL #2 with CORNERS #4 and 1/2" ROUND SCREW #13.

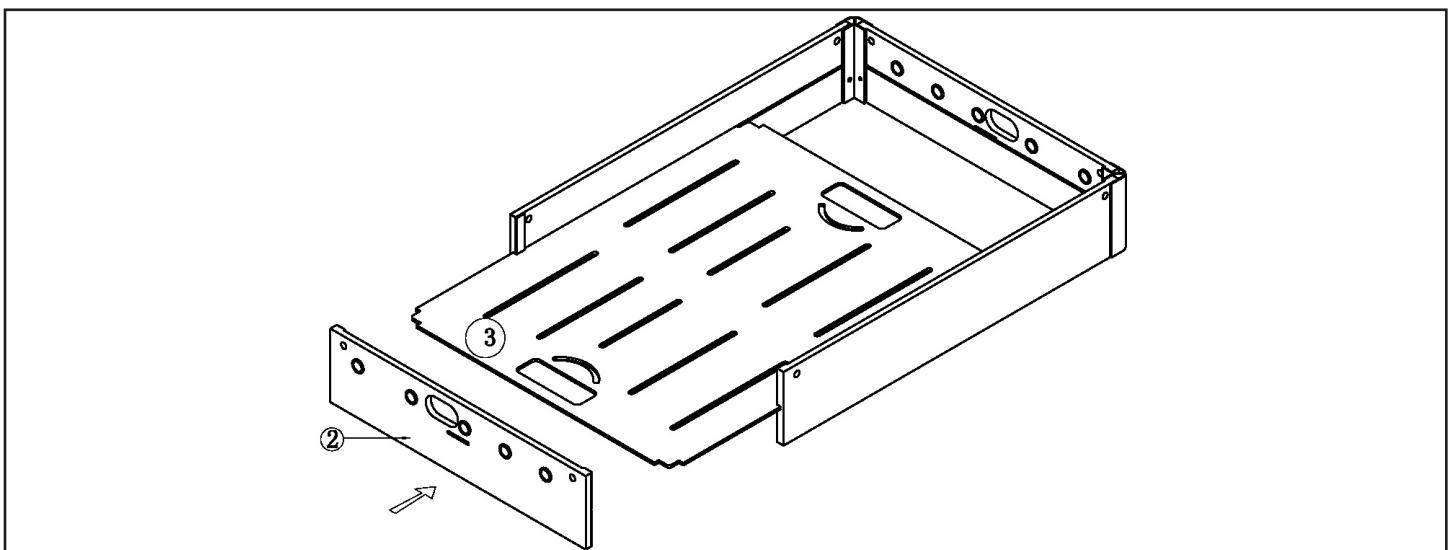

# ASSEMBLY INSTRUCTIONS (CONT.)



4. Attach each PLAYER CONTROL GEAR #17 by inserting tab into PLAYFIELD slots as shown and twisting into place.

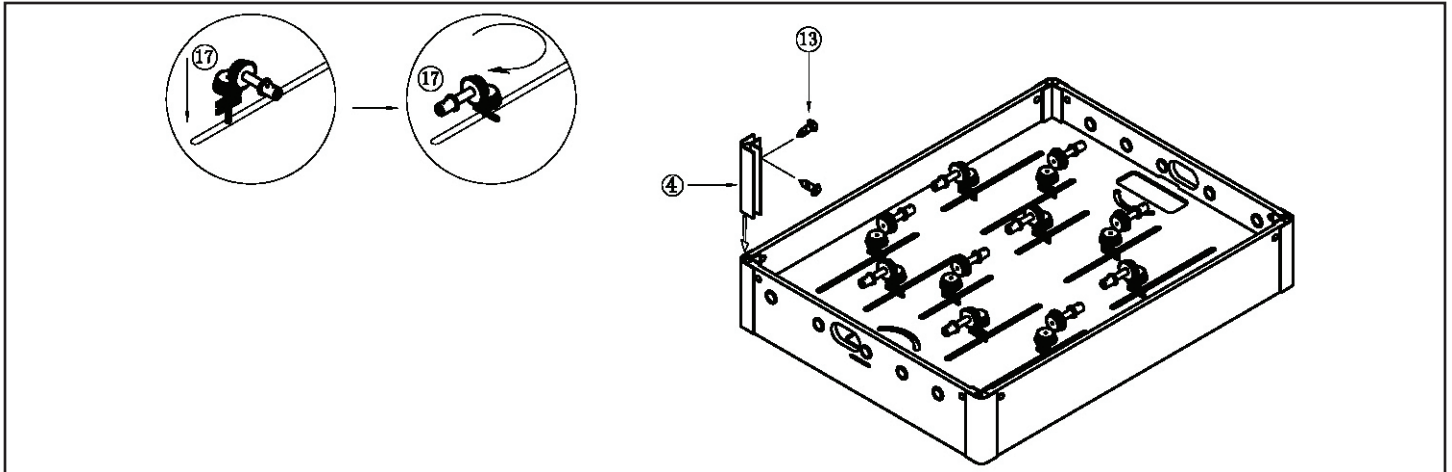

5. Insert LONG PLAYER RODS #25, MEDIUM PLAYER RODS #26 and SHORT PLAYER RODS #27 through END PANELS as shown. *Note: the PLAYER CONTROL GEARS will be secured to the hole in the end of the PLAYER RODS - this end must be inserted into the END PANEL first.*

6. Attach one ROD STOPPER #21 onto each PLAYER ROD with 1/4" ROUND SCREW #33.

7. Secure each PLAYER ROD to installed PLAYER CONTROL GEARS with 1/4" ROUND SCREW #33.

8. Attach ROD BUSHING #23 and HAND GRIP #24 onto each PLAYER ROD.

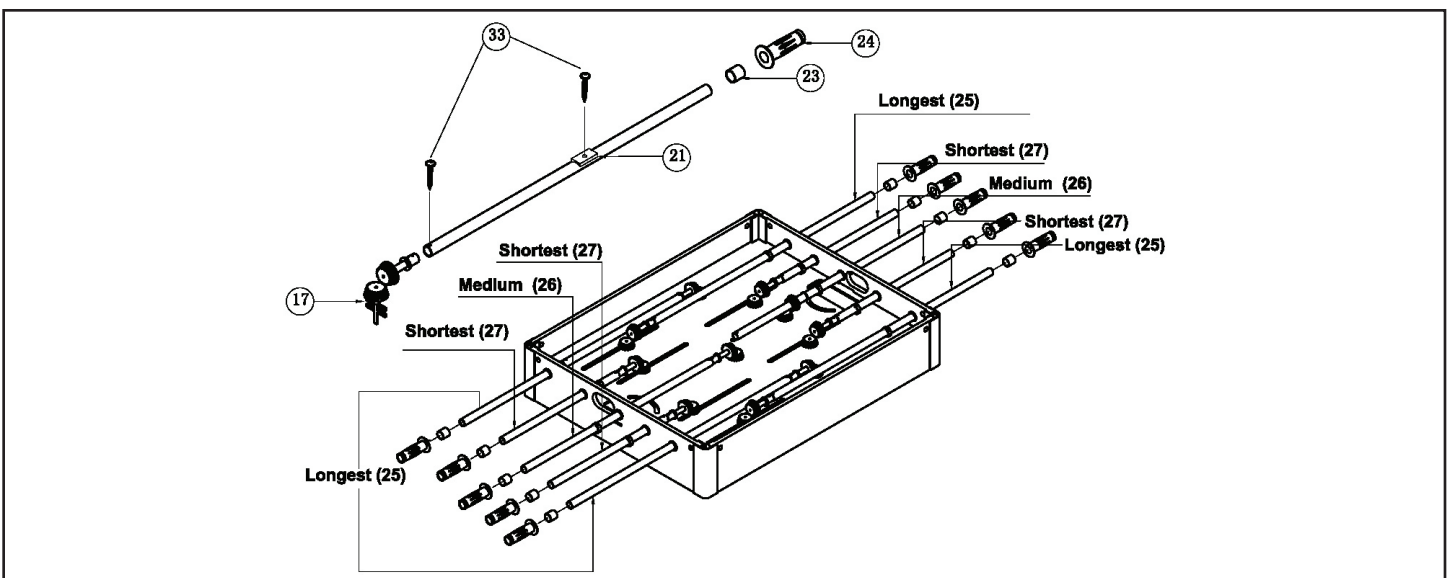

# ASSEMBLY INSTRUCTIONS (CONT.)



9. Position PLAYFIELD SUPPORT BRACE #6 underneath PLAYFIELD and secure to SIDE PANELS with 1" FLAT SCREW #14.

10. Insert one GOALIE CONTROL ARM #18 through one END PANEL and PLAYFIELD. Secure to PLAYFIELD with 3/4" BOLT #15 and NUT #16. Repeat assembly with remaining GOALIE CONTROL ARM.

11. Attach one BALL RETURN BOX #22 to each END PANEL with 1/2" ROUND SCREW #13.

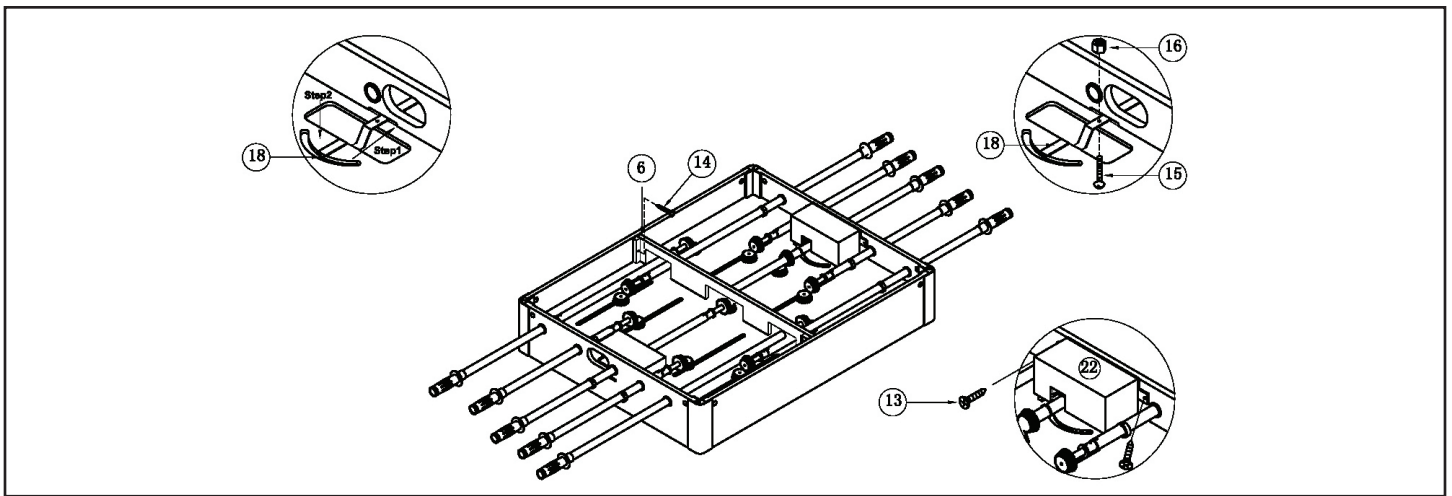

12. Attach one LEG #5 to each corner of the table with 5/16" BOLT #7 and FLAT WASHER #8.

13. Thread one LEG LEVELER #36 onto each LEG. Carefully turn table over.

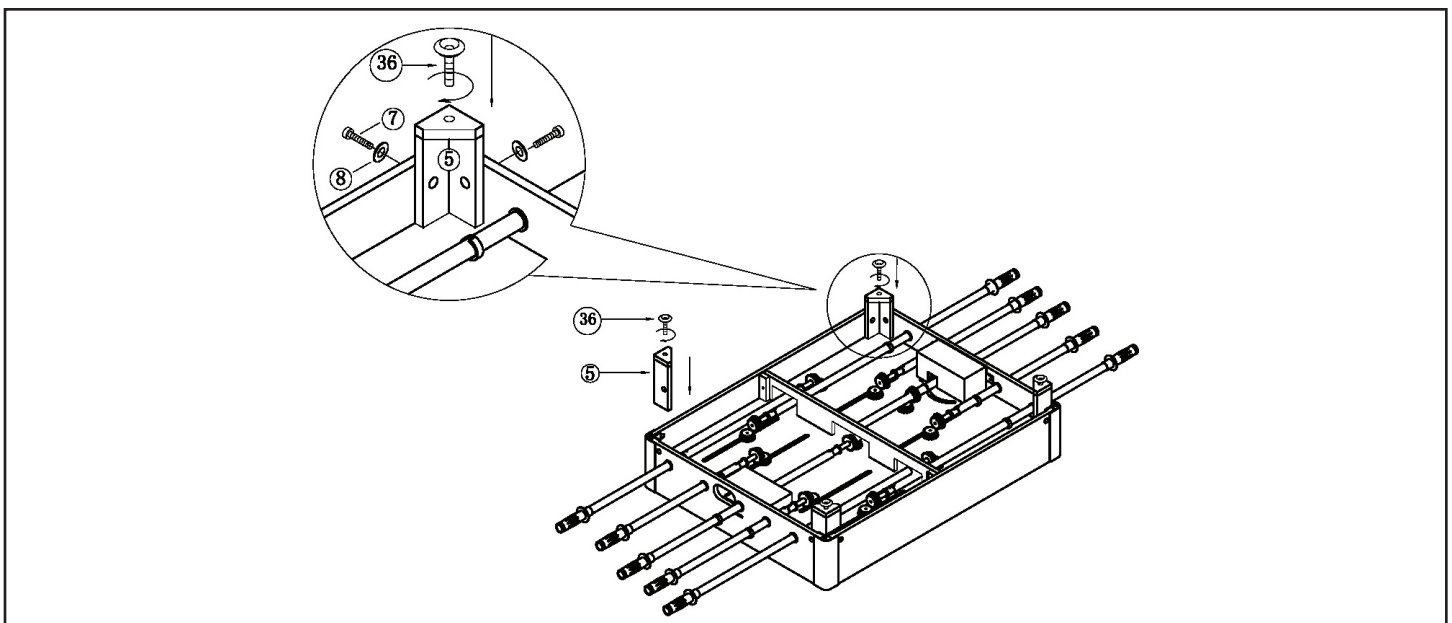





## ASSEMBLY INSTRUCTIONS (CONT.)

14. Attach one SOCCER GOAL #19 to one RIGHT GOAL BORDER #20A and one LEFT GOAL BORDER #20B with 1/2" ROUND SCREW #13. Secure to PLAYFIELD from underneath with 1/2" ROUND SCREW #13. Repeat assembly with remaining SOCCER GOAL and GOAL BORDERS.

15. Attach each PLAYFIELD BORDER #9 to PLAYFIELD from underneath with 1/2" ROUND SCREW #13.

16. Attach BLUE PLAYERS #28 and GREEN PLAYERS #30 as shown by sliding onto exposed tab of appropriate PLAYER CONTROL GEAR.

17. Attach YELLOW GOALIE #29 and RED GOALIE #31 as shown by sliding onto exposed tab of appropriate GOALIE CONTROL ARM.

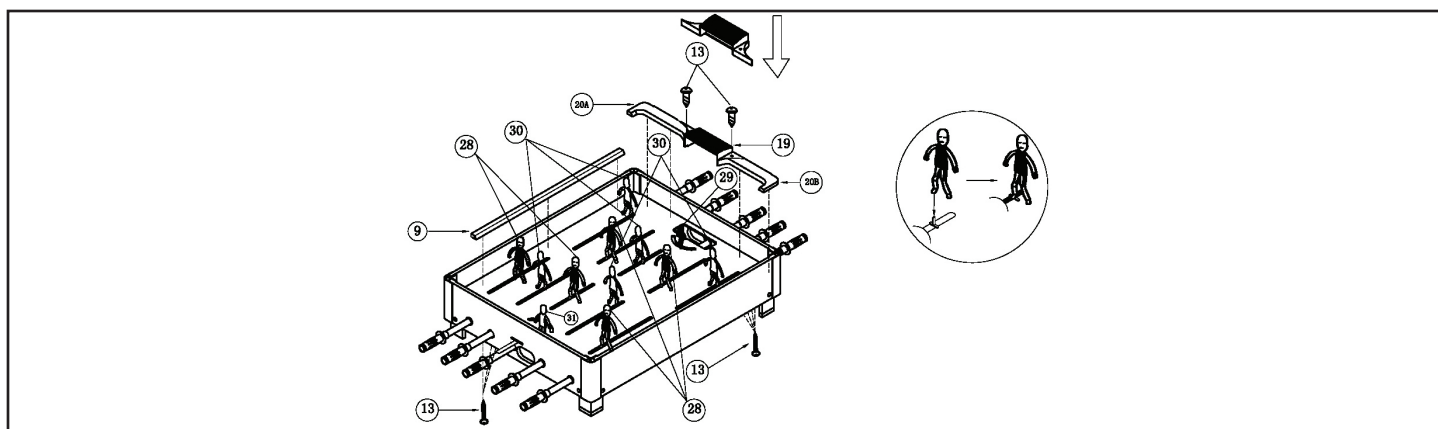

18. Attach one CORNER CAP #34 to each corner of the table with 1/2" ROUND SCREW #13.

19. Attach one MANUAL SCORER #35 to each SIDE PANEL with 1/2" FLAT SCREW #12.

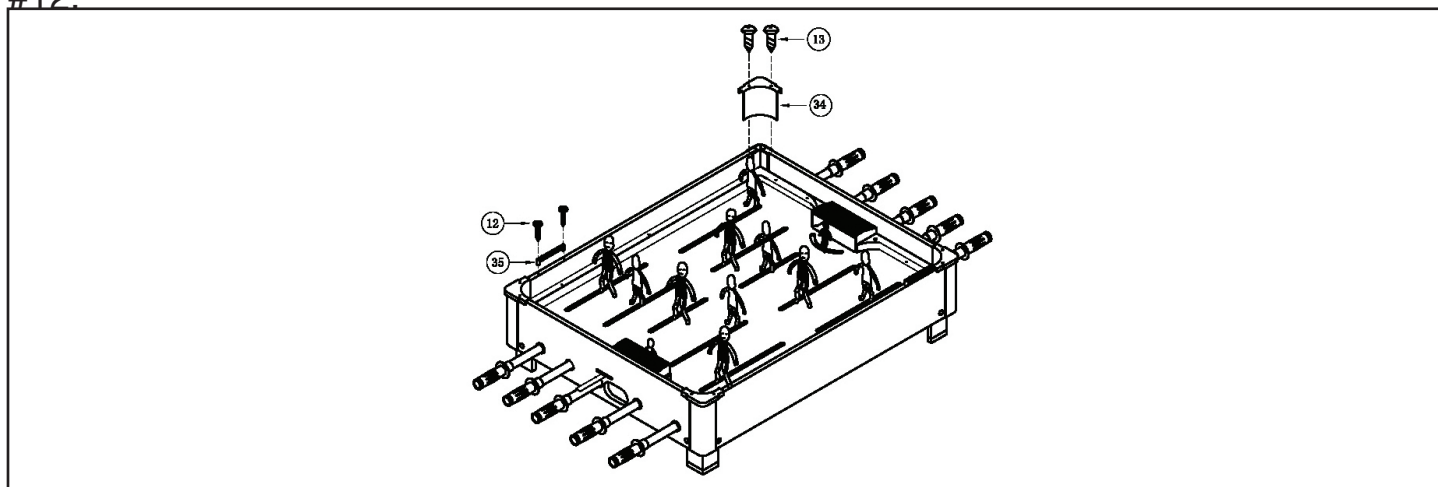

CONGRATULATIONS!



You have now assembled your MLS Soccer Table. Please note the Care and Use instructions below to ensure years of trouble free use of your game table.

## **CARE AND USE**

1. This product is intended for INDOOR use only.
2. Do NOT sit, climb or lean on the table.
3. Do NOT drag the table when moving it as this will damage the legs.

## 90-DAY LIMITED WARRANTY

This Challenger Manufacturing product is warranted to the original purchaser to be free from defects in material or workmanship for a period of ninety days from the date of the original retail purchase.

This warranty does not cover defects or damage due to improper installation, alteration, accident or any other event beyond the control of the manufacturer. Defects or damage resulting from misuse, abuse or negligence will void this warranty. This warranty does not cover scratching or damage that may result from normal usage.

This product is not intended for institutional or commercial use; Challenger Manufacturing does not assume any liability for such use. Institutional or commercial use will void this warranty.

This warranty is nontransferable and is expressly limited to the repair or replacement of the defective product. During the warranty period, Challenger Manufacturing shall repair or replace defective parts at no cost to the purchaser. Shipping charges and insurance are not covered and are the responsibility of the purchaser. Labor charges and related expenses for removal, installation or replacement of the product or components are not covered under this warranty.

Challenger Manufacturing reserves the right to make substitutions to warranty claims if parts or unavailable or obsolete.

Challenger Manufacturing shall not be liable for loss of use of the product or other consequential or incidental costs, expenses or damages incurred by the consumer of any other use. The user assumes all risk of injury resulting from the use of this product.

This warranty is expressly in lieu of all other warranties, expressed or implied, including warranties of merchantability or fitness for use to the extent permitted by Federal or state law. Neither Challenger Manufacturing nor any of its representatives assumes any other liability in connection with this product.

**All warranty claims must be made through the retailer where the product was originally purchased. A purchase receipt or other proof of date of purchase will be required to process all warranty claims. The model number and part numbers found within the assembly instructions will be required when submitting any parts requests or warranty claims.**

**For further warranty information or inquiries, please call 800-759-0977**