

BOUNCE TABLE TENNIS TABLE & ACCESSORIES ASSEMBLY INSTRUCTIONS



NG2325















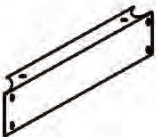
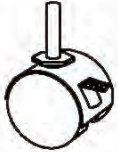

THANK YOU!

Thank you for your purchase of our product.

We work around the clock and around the globe to ensure that our products maintain the highest possible quality. However, in the rare instance that your product is defective or missing parts, contact Challenger Manufacturing at 800-759-0977 to submit parts requests or warranty claims. Please read the warranty information at the back of these assembly instructions for further details.

IMPORTANT! PLEASE READ THESE ASSEMBLY INSTRUCTIONS IN ENTIRETY BEFORE ASSEMBLING YOUR PRODUCT.

PARTS IDENTIFIER (NOT TO SCALE)

<p>#1</p>  <p>TABLE TOP A 1 pc</p>	<p>#2</p>  <p>TABLE TOP B 1 pc</p>	<p>#3</p>  <p>LEG SUPPORT BRACE 4 pcs</p>	<p>#4</p>  <p>CENTER SUPPORT BRACE 2 pcs</p>	<p>#5</p>  <p>SIDE PLATE 2 pcs</p>
<p>#6</p>  <p>WHEEL 4 pcs</p>	<p>#7</p>  <p>LEG BRACKET 4 pcs</p>	<p>#8</p>  <p>SCREW 24 pcs</p>	<p>#9</p>  <p>BOLT SET A 8 pcs</p>	<p>#10</p>  <p>BOLT SET B 8 pcs</p>
<p>#11</p>  <p>BOLT SET C 4 pcs</p>	<p>#12</p>  <p>NET POST 2 pcs</p>	<p>#13</p>  <p>TABLE TENNIS NET 1 pc</p>	<p>#14</p>  <p>PHILLIPS HEAD SCREWDRIVER 1 pc</p>	<p>#15</p>  <p>HEX WRENCH 1 pc</p>
<p>#16</p>  <p>TABLE TENNIS RACKET 2 pcs</p>	<p>#17</p>  <p>TABLE TENNIS BALL 2 pcs</p>			

**IMPORTANT! CAREFULLY OPEN AND RETAIN THE CARDBOARD SHIPPING CARTON.
IT WILL BE USED TO PROTECT THE PLAYING SURFACE DURING ASSEMBLY.**

ASSEMBLY TIPS

1. Find a clean, level surface to begin the assembly of your game table. The table will be partially assembled upside down and then turned over onto its legs. This is a heavy table and turning it over will require at least two strong adults.
2. Remove all of the contents from box and verify that you have all of the parts shown on the Parts Identifier before you begin assembly. **Note: Some parts may be pre-installed or pre-assembled.**
3. Some figures or drawings may not look exactly like your product. Please read and understand the text before beginning each assembly step.
4. When installing parts that have more than one screw or bolt, hand tighten all screws or bolts in place before finishing tightening with screwdriver or hex wrench.
5. Electric screwdrivers may be helpful during assembly; however, please set a low torque and use extreme caution because screws may be stripped or overtightened if the electric screwdriver's torque is set too high.

WARNINGS!

READ AND FOLLOW ALL ASSEMBLY, OPERATION AND SAFETY INSTRUCTIONS CAREFULLY.

CHOKER HAZARD - THIS TABLE CONTAINS SMALL PARTS - NOT SUITABLE FOR CHILDREN UNDER 3 YEARS OF AGE.

ASSEMBLY INSTRUCTIONS

Please note: All bolt and screws should be loosely installed during assembly to allow for movement or adjustment of the parts; The bolts and screws should be fully tightened at the end of assembly, before turning the table over.

1. Lay **TABLE TOP A #1** and **TABLE TOP B #2** upside-down on the cardboard shipping carton to protect the playing surface during assembly. Push the halves together, leaving a 1/2" gap between them at the center line.

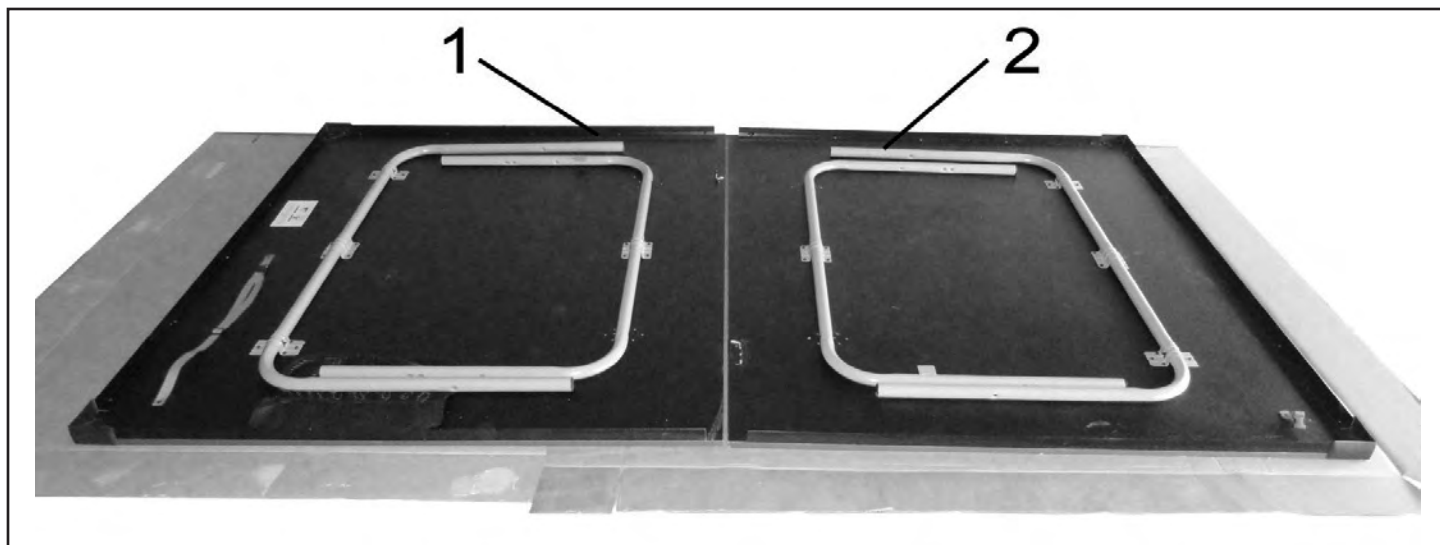

2. Holding the center legs upright, attach each **SIDE PLATE #5** (with the logo upside-down) to the center legs with **BOLT SET B #10**.

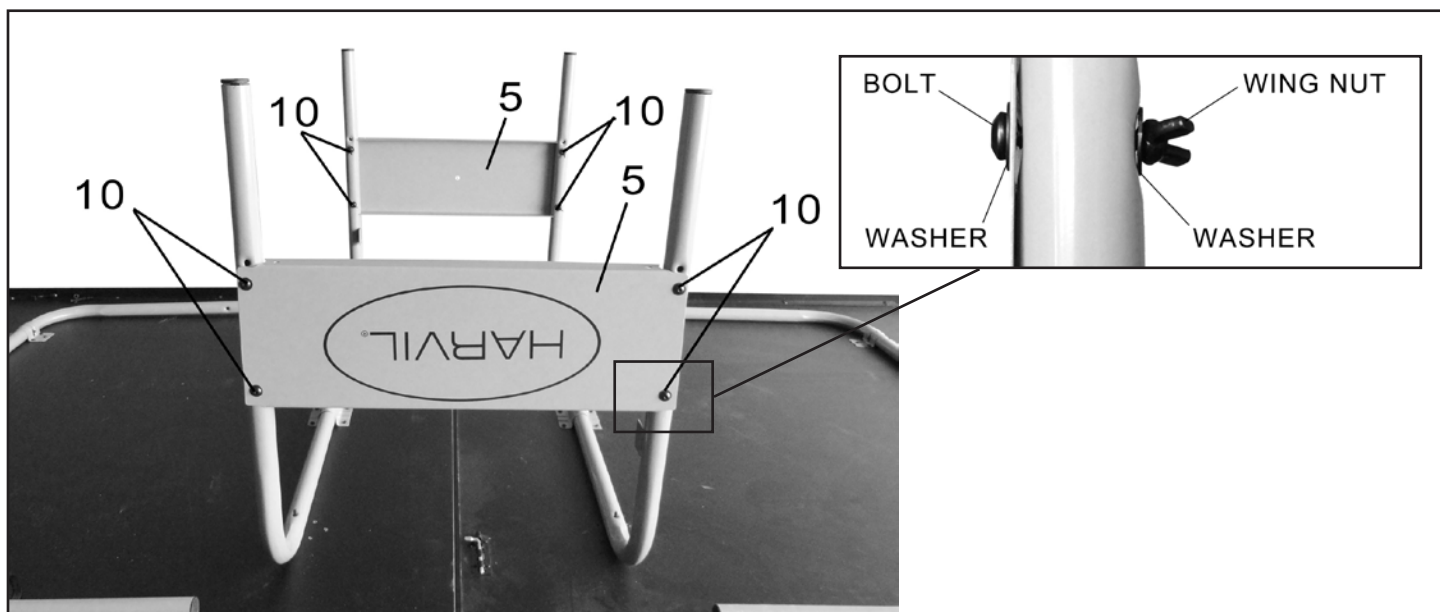

ASSEMBLY INSTRUCTIONS (CONT.)

3. Connect the **SIDE PLATES** with each **CENTER SUPPORT BRACE #4** using **BOLT SET C #11**.

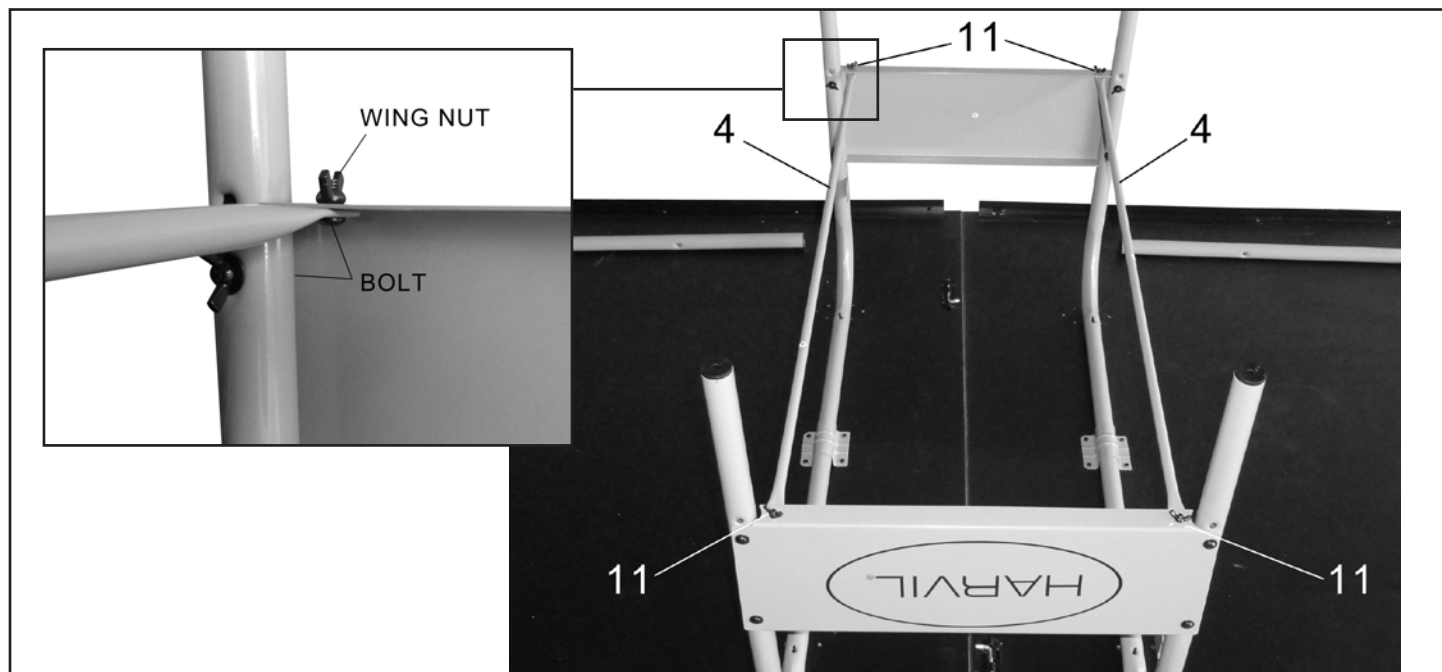

4. Attach each **LEG SUPPORT BRACE #3** with **BOLT SET A #9**.

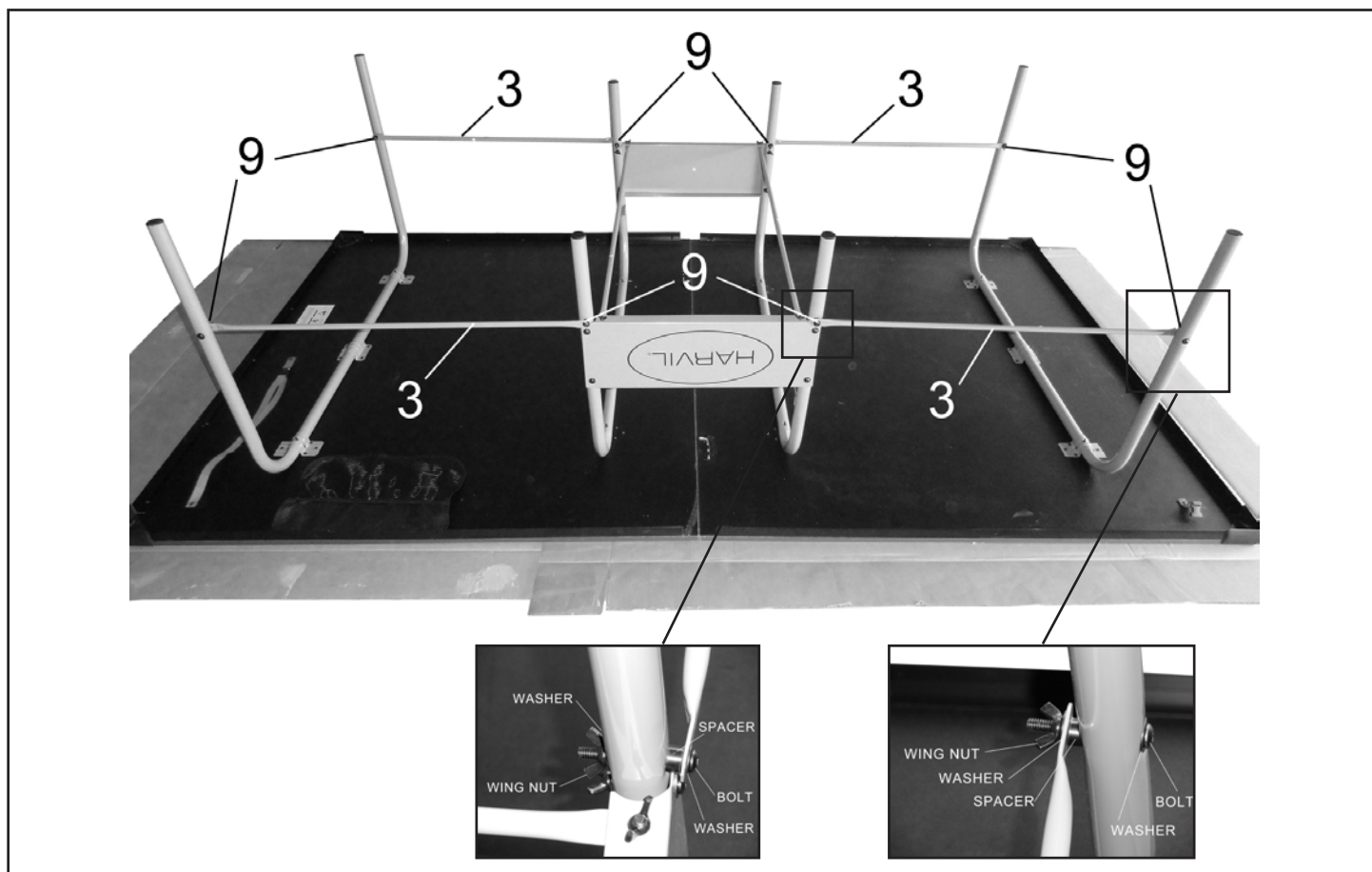

ASSEMBLY INSTRUCTIONS (CONT.)

5. Align two **LEG BRACKETS #7** with the pre-drilled holes in each **TABLE TOP** and attach with **SCREW #8**. *Note: The notched sides of the LEG BRACKETS should face the center line of the table.*

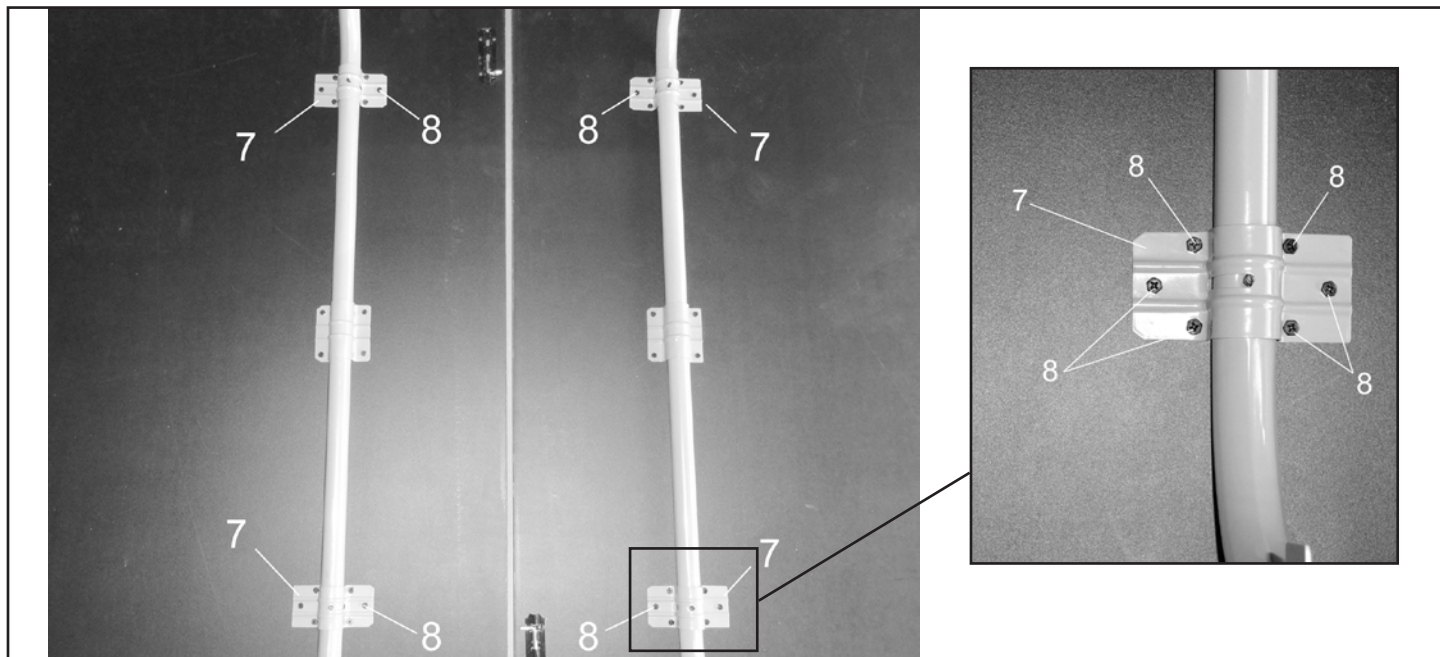

6. Attach one **WHEEL #6** to each of the center legs, pushing down to lock them into place. Tighten all bolts and screws.

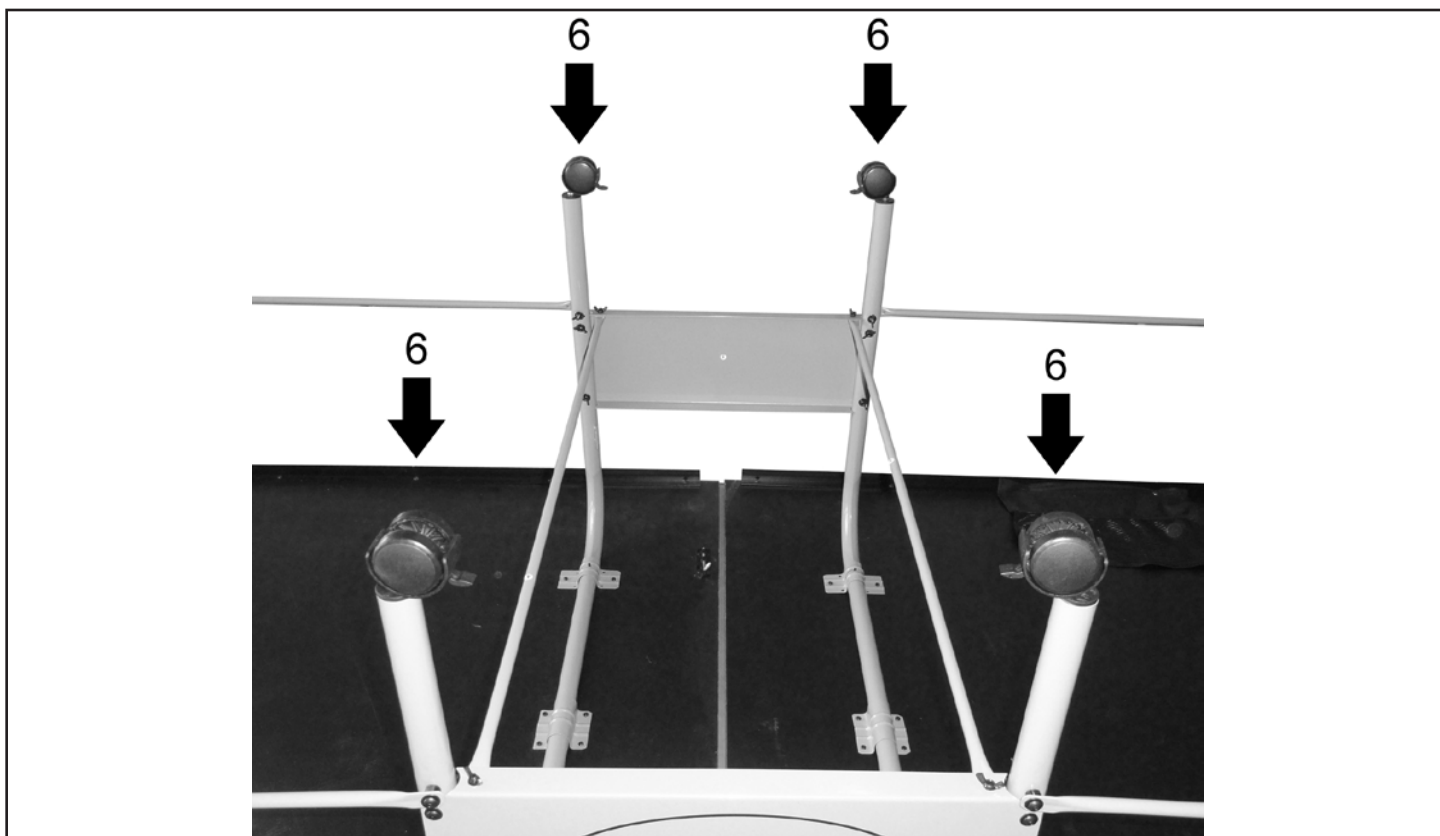

ASSEMBLY INSTRUCTIONS (CONT.)

7. Carefully turn the table over. Clip one **NET POST #12** to each side of the table at the center line. Attach the **TABLE TENNIS NET #13** to each **POST**. *Note: A small gap between the table top halves is normal and will not affect gameplay when the net is in place.*

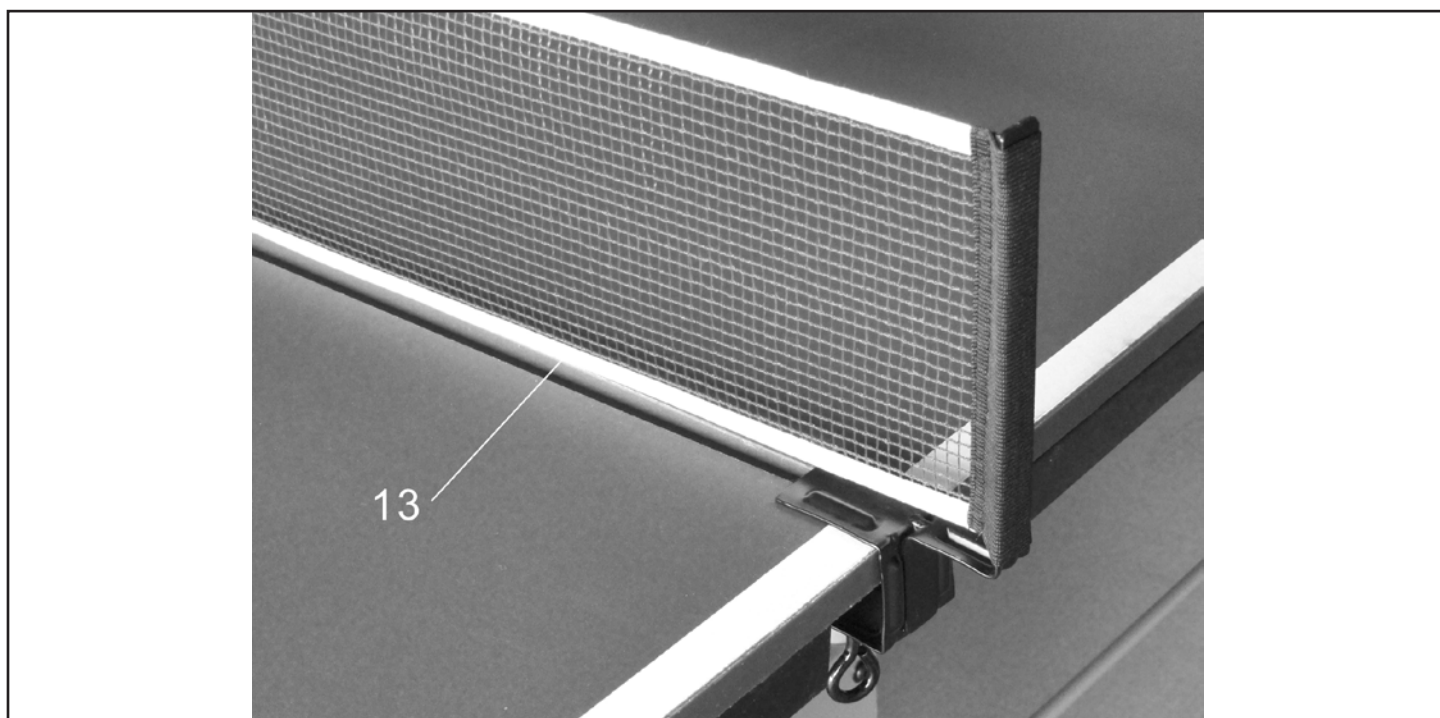
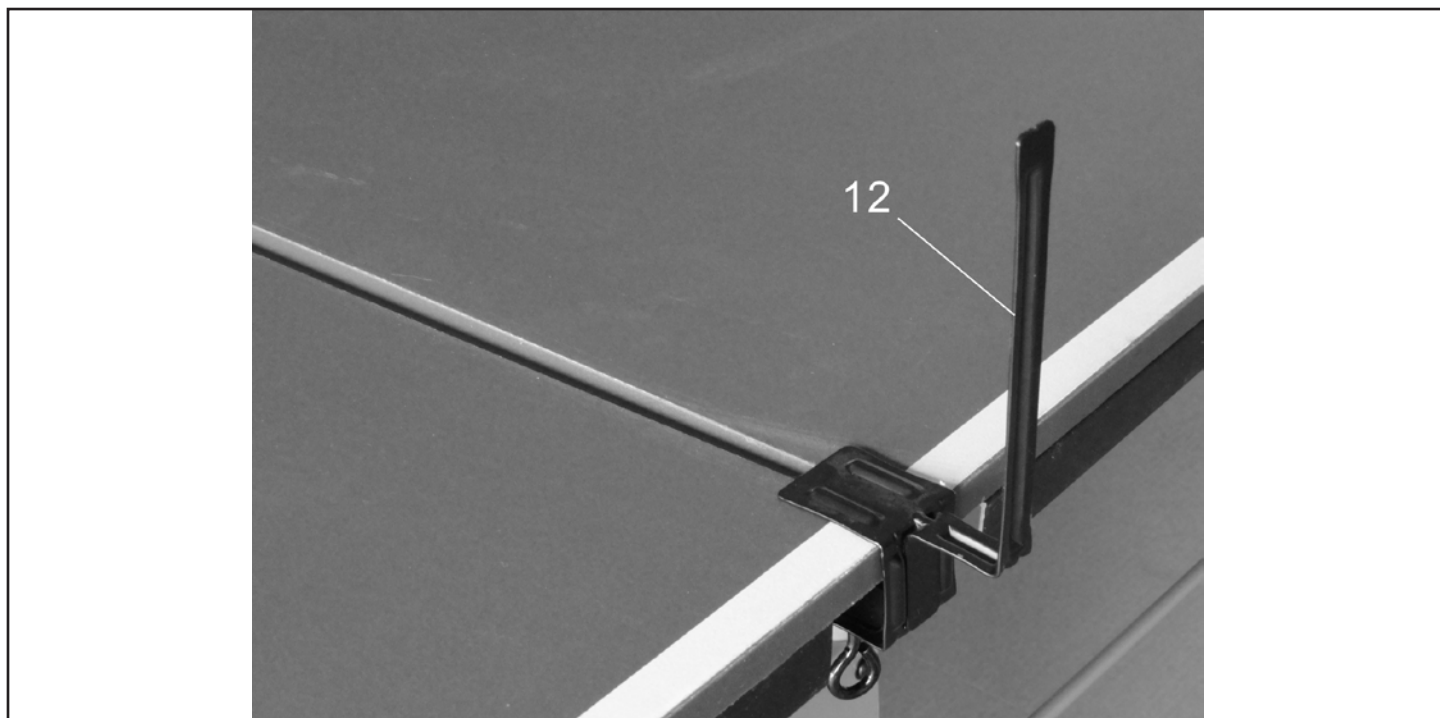

CONGRATULATIONS!

You have now assembled your Game Table. Please note the Care and Use instructions below to ensure years of trouble free use of your game table.

CARE AND USE

1. This product is intended for INDOOR use only.
2. Do NOT sit, climb or lean on the table.
3. ALWAYS lock wheels for game play. Press locking tab down on each wheel to lock. Unlock wheels before moving table. Moving table with wheels in locked position will damage the wheels and legs.
4. For single player practice or playback, fold one side of the table up, fold the legs down and slide the lock into place.

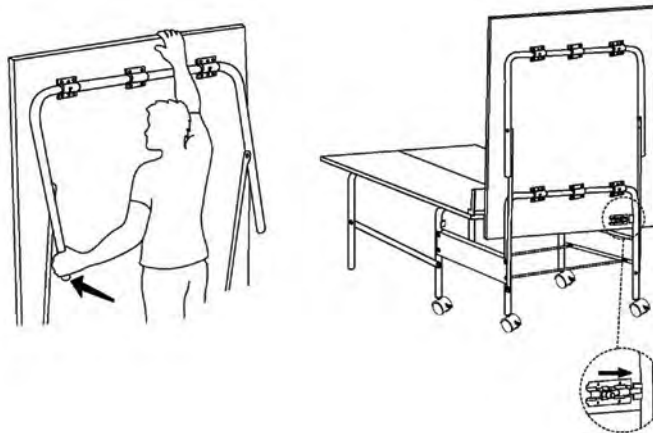

5. To store the table, fold both sides of the table up, fold the legs down and slide each lock into place. Lock the top of table together with the attached clips.

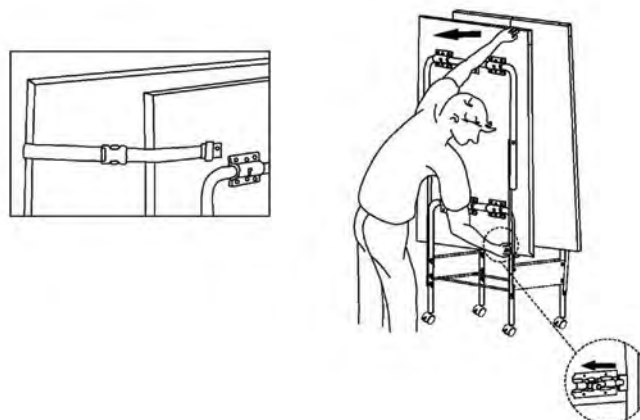

1-YEAR LIMITED WARRANTY

This Challenger Manufacturing product is warranted to the original purchaser to be free from defects in material or workmanship for a period of ninety days from the date of the original retail purchase.

This warranty does not cover defects or damage due to improper installation, alteration, accident or any other event beyond the control of the manufacturer. Defects or damage resulting from misuse, abuse or negligence will void this warranty. This warranty does not cover scratching or damage that may result from normal usage.

This product is not intended for institutional or commercial use; Challenger Manufacturing does not assume any liability for such use. Institutional or commercial use will void this warranty.

This warranty is nontransferable and is expressly limited to the repair or replacement of the defective product. During the warranty period, Challenger Manufacturing shall repair or replace defective parts at no cost to the purchaser. Shipping charges and insurance are not covered and are the responsibility of the purchaser. Labor charges and related expenses for removal, installation or replacement of the product or components are not covered under this warranty.

Challenger Manufacturing reserves the right to make substitutions to warranty claims if parts or unavailable or obsolete.

Challenger Manufacturing shall not be liable for loss of use of the product or other consequential or incidental costs, expenses or damages incurred by the consumer of any other use. The user assumes all risk of injury resulting from the use of this product.

This warranty is expressly in lieu of all other warranties, expressed or implied, including warranties of merchantability or fitness for use to the extent permitted by Federal or state law. Neither Challenger Manufacturing nor any of its representatives assumes any other liability in connection with this product.

All warranty claims must be made through the retailer where the product was originally purchased. A purchase receipt or other proof of date of purchase will be required to process all warranty claims. The model number and part numbers found within the assembly instructions will be required when submitting any parts requests or warranty claims.

For further warranty information or inquiries, please call 800-759-0977